

# RAPIBREW<sup>TM</sup>

FREDDA 1.0

AI Rapid Cold Brew Maker  
Service Guide

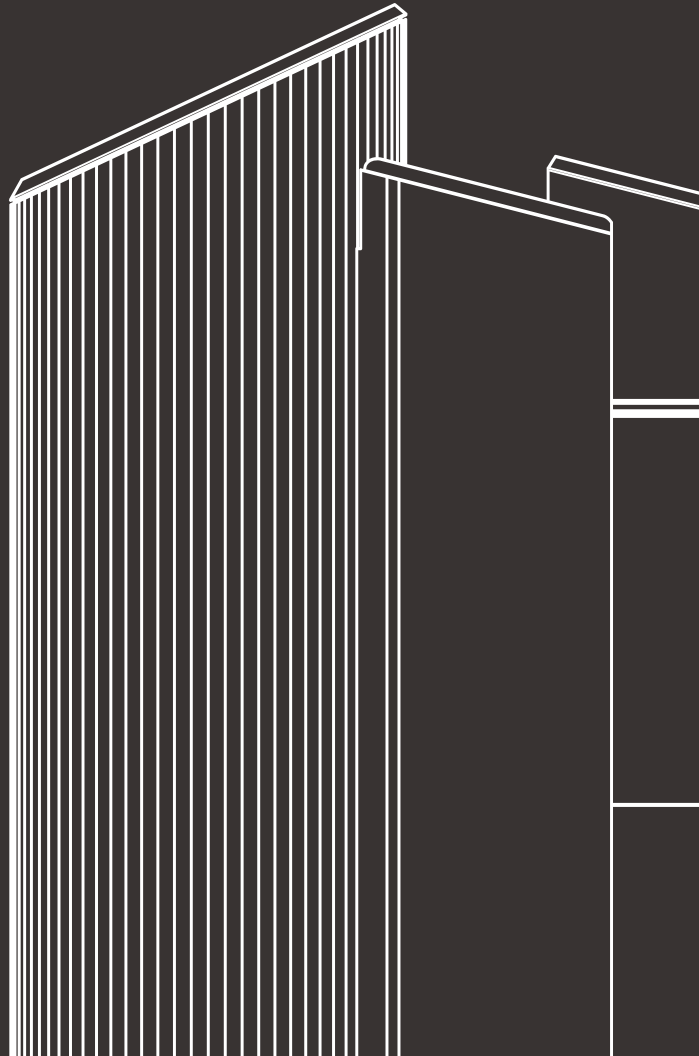



# Contents

---

Contents .....	1
Before Getting Started .....	1
Tools/Equipment Needed .....	1
Pre-Maintenance Preparation .....	2
Diagnosing the Problem .....	5
Maintenance Procedures .....	11
Installing the Top Inner Cover .....	11
Removing the Rear Cover .....	11
Connecting the Antenna .....	14
Replacing the Antenna Module .....	14
Replacing the Mainboard .....	18
Replacing the Power Board .....	20
Replacing the Electromagnetic Valve .....	21
Cleaning the Electromagnetic Valve .....	23
Replacing the Pump .....	25
Opening the Middle Console Cover .....	28
Replacing the Middle Console Sensor Board .....	30
Replacing the Lower Pot Cover Motor .....	31
Correcting the Lower Pot Cover Pressure .....	33
Securing the Lower Pot Cover Motor .....	35
Cleaning/Replacing the Liquid Intake/Output Tubes .....	36

Removing the Top Cover .....	38
Replacing the Hinge Board .....	42
Replacing the Stirrer Motor .....	42
Securing the Stirrer Motor .....	46
Replacing the Plastic Rotary Head .....	47
Replacing the Button Board .....	49
Removing the Hinge .....	50
Replacing the 6-Pin Stirrer Motor Cable .....	51
Replacing the 12-Pin Button Board Cable .....	52
Replacing the Lower Pot Sensor Board .....	53
Replacing the 12-Pin Daughter Board Cable .....	55
Cable Routing .....	59
Stirrer Motor and Button Board Cable .....	59
12-Pin Daughter Board Cable .....	61
Lower Pot Cover Motor Cable .....	63



# Before Getting Started

---

Read the following sections in their entirety before you get started on any maintenance procedures to ensure that the entire process proceeds smoothly and without any issues.

## Tools/Equipment Needed

Ensure that you have the following tools at your disposal.

- One Phillips head screw driver in the following sizes each:
  - #1 5mm x 8" / Length: 290mm / Handle Length: 85mm
  - #2 6mm x 8" / Length: 290mm / Handle Length: 85mm
- One soldering gun
- One utility knife
- One pair of needle-nose pliers
- Several spare plastic cable ties
- One plastic cushion or mat
- One hot glue gun and hot glue stick.
- One tube of polyurethane multi-material composite adhesive (as shown in the image below)



# Pre-Maintenance Preparation

Prior to starting any maintenance procedures ensure that you have done the following:

1. Fill the upper pot with clean water and then start the self-cleaning mode on the machine to clean its tubes.
2. Power off the machine.
3. Unplug the machine from any power outlet.
4. Cover your workspace with the plastic cushion or mat and perform all procedures on it.
5. Remove the stirrer from the top cover.

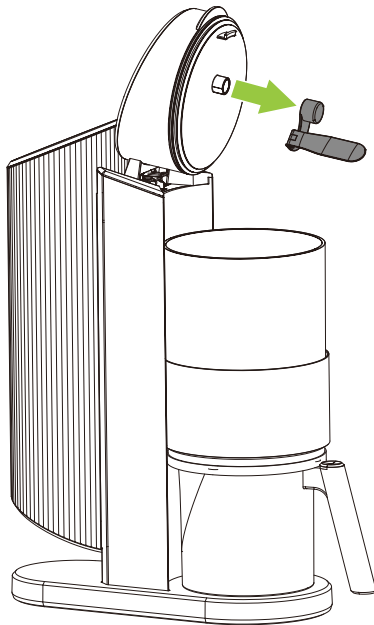

6. Remove the upper and lower pot from the machine.

7. Check if the O-ring is installed in the middle console cover by sticking your finger into the opening at the center of the ground tray and feel if the O-ring seal is in place in its compartment inside the ground tray. If the O-ring is out of place or dislodged, please contact the vendor for a replacement O-ring.

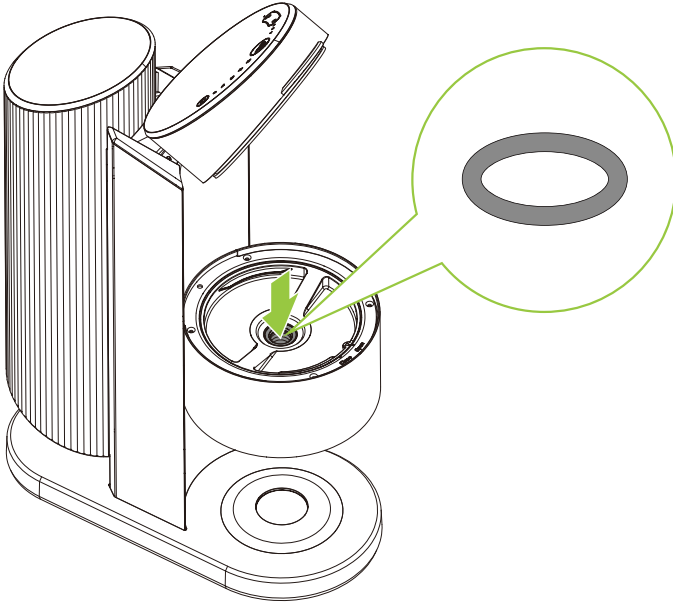

8. Ensure that the following four screws at the base panel of the machine are secured tightly.

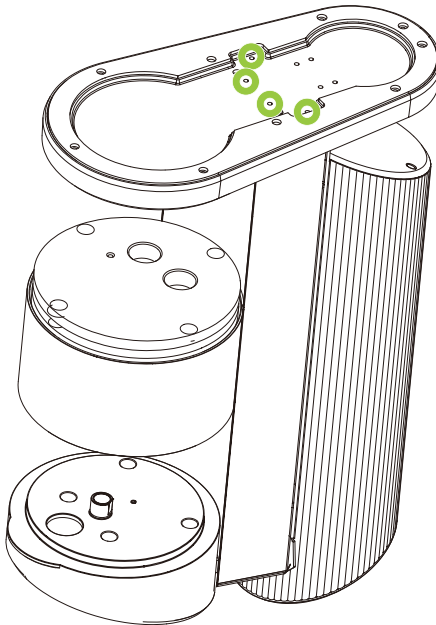

9. Anytime the rear cover is removed during maintenance procedures, immediately ensure that the following four screws inside the machine are secured tightly.

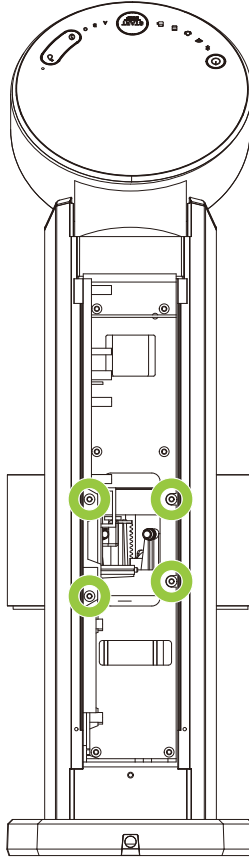

# Diagnosing the Problem

---

The table below identifies issues with the machine that may require maintenance along with the corresponding procedures which may help resolve the issue.

When you encounter any of the issues below, proceed with the first suggested solution listed. Once you have completed the respective procedure, check to see if the issue is resolved. If the issue still persists, proceed with the subsequent solution listed and so on until the issue is resolved.

If the issue still persists after all the solutions have been attempted, please contact the vendor for further assistance.

Issue	Possible Cause	Suggested Solution
The power button is unresponsive.	<ol style="list-style-type: none"><li>1. The mainboard is faulty.</li><li>2. The button board is faulty.</li><li>3. The 12-pin button board cable is faulty.</li><li>4. The power board is faulty.</li></ol>	<ol style="list-style-type: none"><li>1. Replace the mainboard. See “Replacing the Mainboard” on page 18 for instructions.</li><li>2. Replace the button board. See “Replacing the Button Board” on page 49 for instructions.</li><li>3. Replace the 12-pin button board cable. See “Replacing the 12-Pin Button Board Cable” on page 52 for instructions.</li><li>4. Replace the power board. See “Replacing the Power Board” on page 20 for instructions.</li></ol>
When the machine is operating, the electromagnetic valve can be heard working but no coffee drips into the lower pot.	<ol style="list-style-type: none"><li>1. The electromagnetic valve is clogged with coffee grounds.</li><li>2. The electromagnetic valve is faulty.</li></ol>	<ol style="list-style-type: none"><li>1. Clean the electromagnetic valve. See “Cleaning the Electromagnetic Valve” on page 23 for instructions.</li><li>2. Replace the electromagnetic valve. See “Replacing the Electromagnetic Valve” on page 21 for instructions.</li></ol>

Issue	Possible Cause	Suggested Solution
The lower pot cover does not descend properly.	<ol style="list-style-type: none"> <li>1. The lower pot cover motor is not installed correctly.</li> <li>2. The lower pot cover motor is faulty.</li> <li>3. The mainboard is faulty.</li> </ol>	<ol style="list-style-type: none"> <li>1. Ensure that the lower pot cover motor is secured properly. See “Securing the Lower Pot Cover Motor” on page 35 for instructions.</li> <li>2. Replace the lower pot cover motor. See “Replacing the Lower Pot Cover Motor” on page 31 for instructions.</li> <li>3. Replace the mainboard. See “Replacing the Mainboard” on page 18 for instructions.</li> </ol>
When the pump is supposed to be operating, it does not fluctuate between a high and low frequency so it does not sound like there is any suction occurring.	<ol style="list-style-type: none"> <li>1. The lower pot has not been properly pressure sealed.</li> <li>2. The lower pot cover motor is faulty.</li> </ol>	<ol style="list-style-type: none"> <li>1. Correct the lower pot cover pressure. See “Correcting the Lower Pot Cover Pressure” on page 33 for instructions.</li> <li>2. Replace the lower pot cover motor. See “Replacing the Lower Pot Cover Motor” on page 31 for instructions.</li> </ol>
The stirrer is not rotating.	<ol style="list-style-type: none"> <li>1. Plastic rotary head is faulty.</li> <li>2. The stirrer motor is not installed correctly.</li> <li>3. The 6-pin stirrer motor cable is faulty.</li> <li>4. The mainboard is faulty.</li> </ol>	<ol style="list-style-type: none"> <li>1. Replace the plastic rotary head. See “Replacing the Plastic Rotary Head” on page 47 for instructions.</li> <li>2. Ensure that the stirrer motor is secured properly. See “Securing the Stirrer Motor” on page 46 for instructions.</li> <li>3. Replace the 6-pin stirrer motor cable. See “Replacing the 6-Pin Stirrer Motor Cable” on page 51 for instructions.</li> <li>4. Replace the mainboard. See “Replacing the Mainboard” on page 18 for instructions.</li> </ol>

Issue	Possible Cause	Suggested Solution
The pump is not working.	<ol style="list-style-type: none"> <li>1. The pump is faulty.</li> <li>2. The mainboard is faulty.</li> </ol>	<ol style="list-style-type: none"> <li>1. Replace the pump. See “Replacing the Pump” on page 25 for instructions.</li> <li>2. Replace the mainboard. See “Replacing the Mainboard” on page 18 for instructions.</li> </ol>
The start button does not light up.	<ol style="list-style-type: none"> <li>1. The upper and lower pot are not placed correctly into their compartments.</li> <li>2. The 12-pin button board cable is faulty.</li> <li>3. The button board is faulty.</li> </ol>	<ol style="list-style-type: none"> <li>1. Place the upper and lower pots correctly into their compartments.</li> <li>2. Replace the 12-pin button board cable. See “Replacing the 12-Pin Button Board Cable” on page 52 for instructions.</li> <li>3. Replace the button board. See “Replacing the Button Board” on page 49 for instructions.</li> </ol>
The start button lights up but is unresponsive.	<ol style="list-style-type: none"> <li>1. The 12-pin button board cable is faulty.</li> </ol>	<ol style="list-style-type: none"> <li>1. Replace the 12-pin button board cable. See “Replacing the 12-Pin Button Board Cable” on page 52 for instructions.</li> </ol>

Issue	Possible Cause	Suggested Solution
The upper pot light does not light up.	<ol style="list-style-type: none"> <li>1. The top inner cover is not installed.</li> <li>2. The upper pot is not fully placed into the compartment.</li> <li>3. The four screws for the middle console cover are not secured correctly.</li> <li>4. The hinge board is faulty.</li> <li>5. The middle console sensor board on the faulty.</li> <li>6. The 12-pin daughter board cable is faulty.</li> </ol>	<ol style="list-style-type: none"> <li>1. Install the top inner cover onto the top cover. See “Installing the Top Inner Cover” on page 11 for more instructions.</li> <li>2. Place the upper pot correctly into its compartment.</li> <li>3. Ensure that the four screws for the middle console cover are only tightened so that the heads of each screw are level with its adjacent surface and are not screwed too tightly. See step 1 in the “Opening the Middle Console Cover” on page 28 for more instructions.</li> <li>4. Replace the hinge board. See “Replacing the Hinge Board” on page 42 for instructions.</li> <li>5. Replace the middle console sensor board. See “Replacing the Middle Console Sensor Board” on page 30 for instructions.</li> <li>6. Replace the 12-pin daughter board cable. See “Replacing the 12-Pin Daughter Board Cable” on page 55 for instructions.</li> </ol>
The lower pot light does not light up.	<ol style="list-style-type: none"> <li>1. The lower pot sensor board is faulty.</li> <li>2. The 12-pin daughter board cable is faulty.</li> </ol>	<ol style="list-style-type: none"> <li>1. Replace the lower pot sensor board. See “Replacing the Lower Pot Sensor Board” on page 53 for instructions.</li> <li>2. Replace the 12-pin daughter board cable. See “Replacing the 12-Pin Daughter Board Cable” on page 55 for instructions.</li> </ol>



Issue	Possible Cause	Suggested Solution
The Wi-Fi light does not light up.	<ol style="list-style-type: none"> <li>1. The Wi-Fi antenna is not connected properly.</li> <li>2. The Wi-Fi module is faulty.</li> <li>3. The 12-pin button board cable is faulty.</li> <li>4. The button board is faulty.</li> </ol>	<ol style="list-style-type: none"> <li>1. Connect the antenna. See “Connecting the Antenna” on page 14 for instructions.</li> <li>2. Replace the mainboard. See “Replacing the Mainboard” on page 18 for instructions.</li> <li>3. Replace the 12-pin button board cable. See “Replacing the 12-Pin Button Board Cable” on page 52 for instructions.</li> <li>4. Replace the button board. See “Replacing the Button Board” on page 49 for instructions.</li> </ol>
The red light keeps flashing,	<ol style="list-style-type: none"> <li>1. The machine was forced to power off in the middle of the previous session, so the pressure in the lower pot is not at the proper level during the current powering on process and as a result the machine is in the process of readjusting the pressure.</li> <li>2. The pressure sensor is faulty.</li> </ol>	<ol style="list-style-type: none"> <li>1. Wait for some time, once the middle console/lower pot cover elevates, the machine will working properly.</li> <li>2. Replace the mainboard. See “Replacing the Mainboard” on page 18 for instructions.</li> </ol>

Issue	Possible Cause	Suggested Solution
<p>The red light is solid red.</p>	<ol style="list-style-type: none"> <li>1. The power current for the stirrer motor is too high.</li> <li>2. The power current for the lower pot cover motor is too high.</li> <li>3. The power current for the pump is too high.</li> <li>4. The power current for the electromagnetic valve is too high.</li> </ol>	<ol style="list-style-type: none"> <li>1. Replace the stirrer motor. DO NOT replace the mainboard. See “Securing the Stirrer Motor” on page 46 for instructions.</li> <li>2. Replace the lower pot cover motor. DO NOT replace the mainboard. See “Replacing the Lower Pot Cover Motor” on page 31 for instructions.</li> <li>3. Replace the pump. DO NOT replace the mainboard. See “Replacing the Pump” on page 25 for instructions.</li> <li>4. Replace the electromagnetic valve. DO NOT replace the mainboard. See “Replacing the Electromagnetic Valve” on page 21 for instructions.</li> </ol>

# Maintenance Procedures

---

## Installing the Top Inner Cover

Align the hole in the top inner cover to the knob for the stirrer and then place the top inner cover onto the top cover so that the magnets lock it in place.

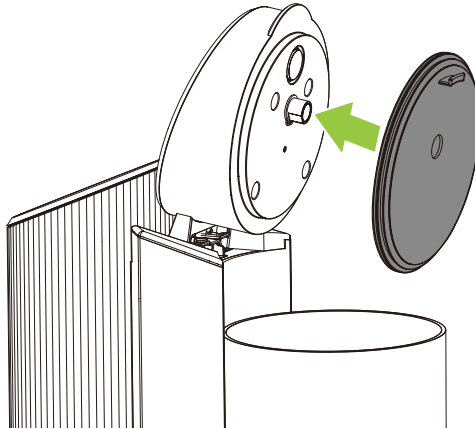

## Removing the Rear Cover

1. Remove the single M3x14 round Phillips head self-tapping Nylok screw and two M3x6 round Phillips head machine-tapping screws securing the bottom cap in place and then remove the bottom cap from the rear cover.

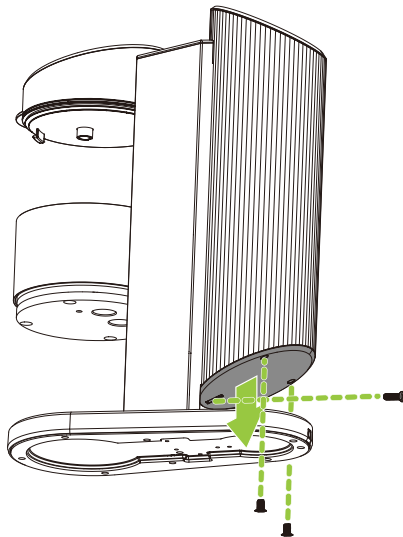

2. Remove the two M2.5x6 round Phillips head machine-tapping screws securing the rear cover in place.

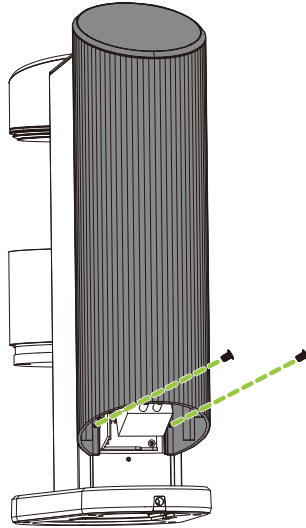

3. Lift the rear cover upwards to release it from the machine.

**⚠ CAUTION:** DO NOT attempt to completely remove the cover at this point, as this will damage the antenna cable. Only lift the cover enough to release it from the machine (within a 10cm range).

**✓ NOTE:** If the cover is secured too tightly to the machine and you are unable to lift it, push it upwards from its bottom side.

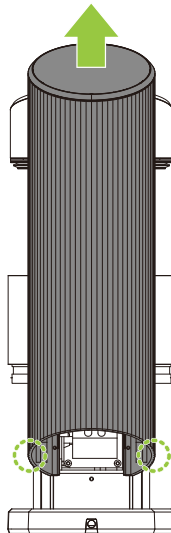

- Carefully separate the rear cover slightly from the machine.

**⚠ CAUTION:** DO NOT pull or attempt to completely remove the cover at this point, as this will damage the antenna cable.

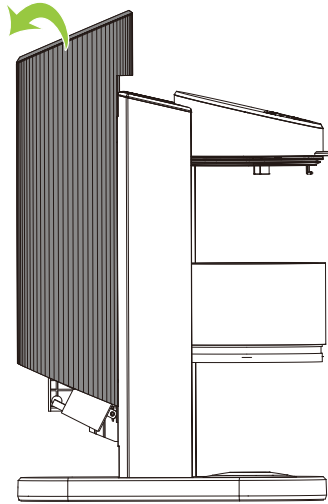

- Disconnect the (A) 6-pin light board cable and (B) the wireless antenna cable from the mainboard and then remove the rear cover from the machine.

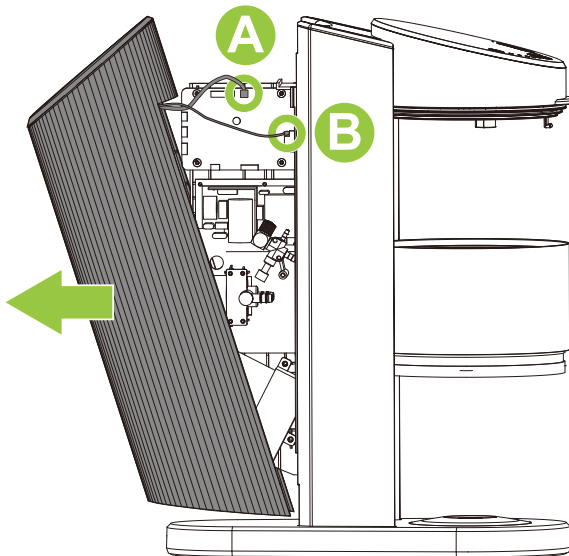

To re-install the rear cover, reverse the steps above.

# Connecting the Antenna

1. Follow steps 1 - 4 in “Removing the Rear Cover” on page 11.
2. Ensure that the antenna cable is properly connected to the connector on the mainboard.

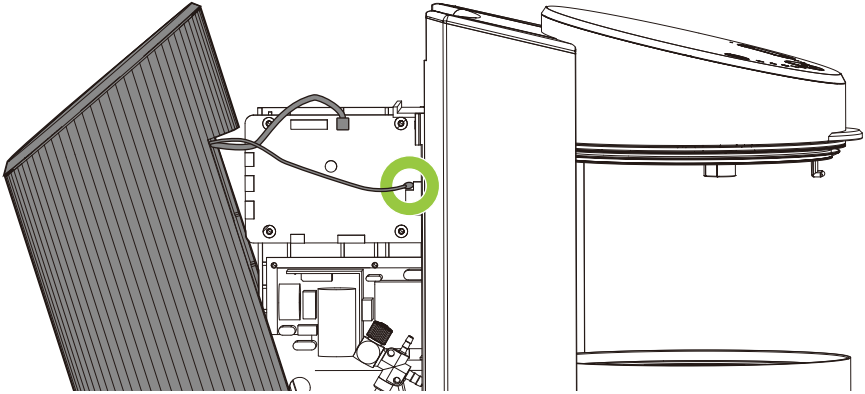

3. Reverse the steps in “Removing the Rear Cover” on page 11 to re-install the rear cover.

# Replacing the Antenna Module

1. Remove the rear cover from the machine. See “Removing the Rear Cover” on page 11 for instructions.
2. Insert a utility knife into the bottom side of the cosmetic logo sticker on the status light panel.

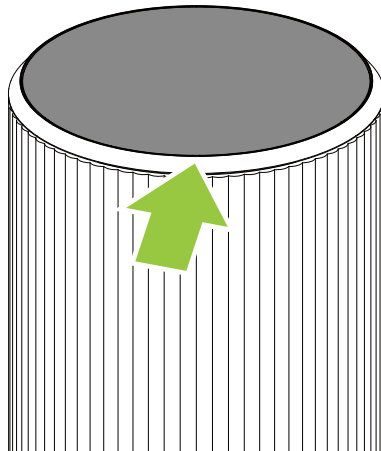

3. Work your way around the edges of the cosmetic logo sticker with the utility knife to detach its adhesive from the light panel.

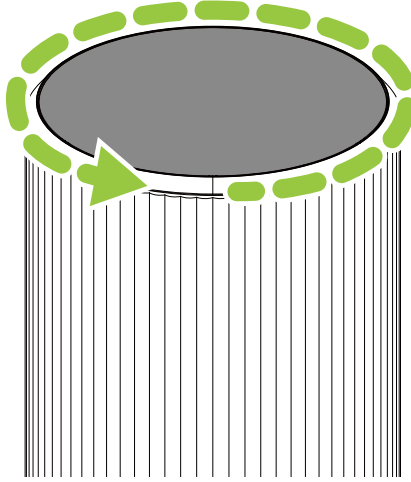

4. Peel off the cosmetic logo sticker from the light panel.

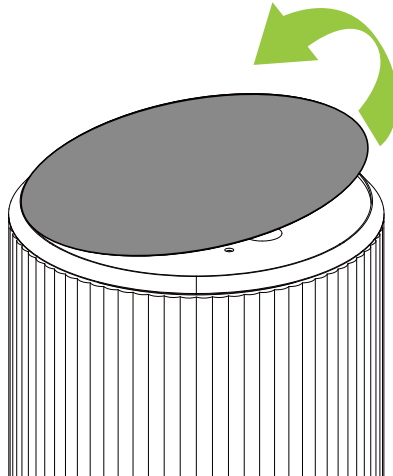

- ✓ NOTE:** When re-adhering the cosmetic logo sticker to the light panel, ensure that the four protrusions on the under side of the sticker fit into the four holes on the panel.

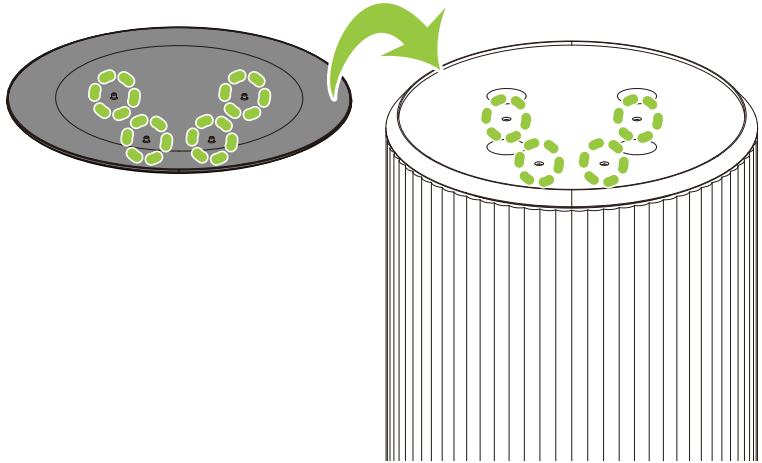

5. Remove the four M2.5x6 round Phillips head machine-tapping screws securing the light panel in place and then remove the panel from the rear cover.

- ✓ NOTE:** When re-installing the light panel to the rear cover, ensure that the four alignment holes on the panel are facing the outer side of the rear cover.

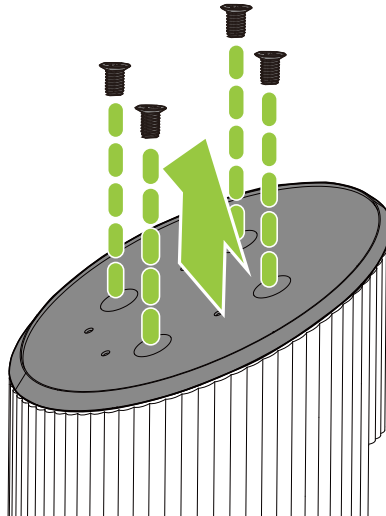



6. Remove the four black M2.5x5 round Phillips head self-tapping screws securing the antenna cover in place and then remove the antenna cover.

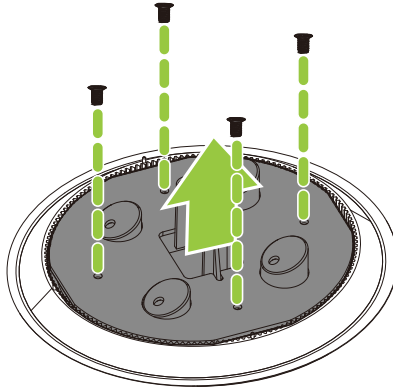

7. Peel off the antenna module from the light panel.

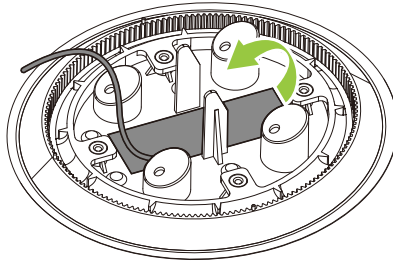

**✓ NOTE:** When re-adhering the antenna module to the light panel, ensure that the side with the antenna cable is oriented to the front side of the light panel.

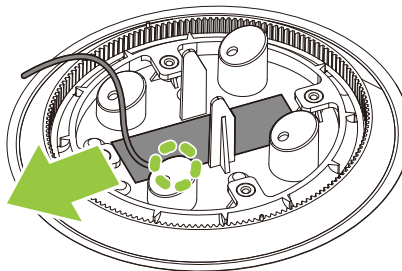

To install the antenna module, reverse the steps above.

# Replacing the Mainboard

1. Remove the rear cover from the machine. See “Removing the Rear Cover” on page 11 for instructions.
2. Disconnect the (A) 12-pin daughter board cable, (B) 3-pin lower pot cover motor cable, (C) 2-pin electromagnetic valve cable, (D) 3-pin pump cable, (E) 2-pin power cable, and (F) 6-pin stirrer motor cable from the mainboard.

**✓ NOTE:** The 12-pin daughter board cable connector features a latch that requires the user to pinch in order to disconnect it from the mainboard.

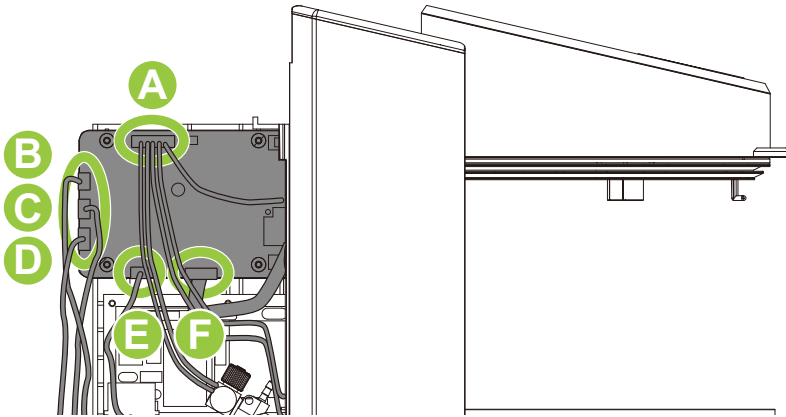

3. Pull the lower pot pressure sensor tube to detach it from the mainboard.

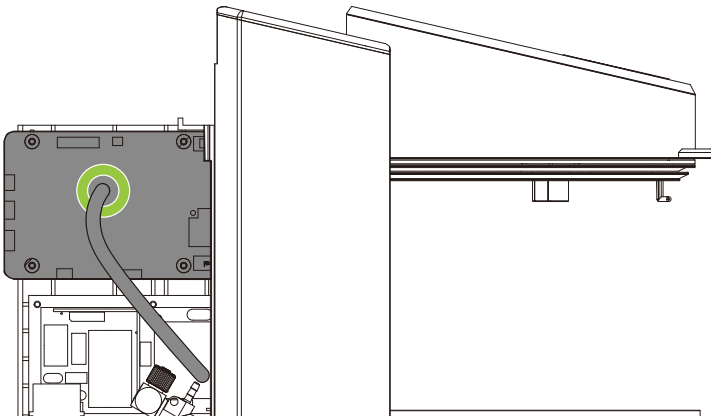

**✓ NOTE:** When re-attaching the tube, first use scissors to slightly cut the top off the remnants of the urethane adhesive gel on the mainboard, then re-apply some new urethane gel over the top of the connection point for the tube.

4. Remove the four black M2.5x5 round Phillips head self-tapping screws securing the mainboard in place and then carefully separate the mainboard from its compartment.

**⚠ CAUTION:** DO NOT pull or attempt to completely remove the mainboard at this point as this will damage the 12-pin operation panel cable.

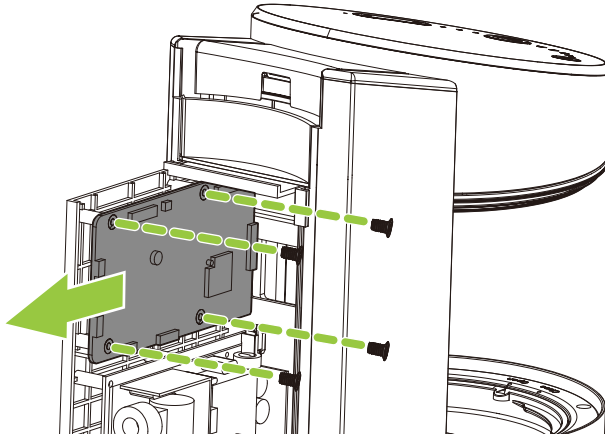

5. Disconnect the 12-pin operation panel cable from the mainboard, and then remove the mainboard from the machine.

**✓ NOTE:** The cable connector features a latch that requires the user to pinch in order to disconnect it from the mainboard.

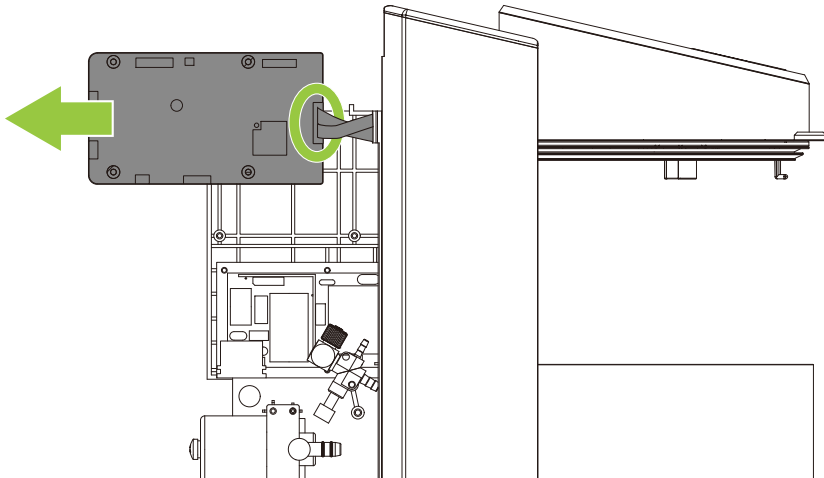

To install the mainboard, reverse the steps above.

# Replacing the Power Board

1. Remove the rear cover from the machine. See "Removing the Rear Cover" on page 11 for instructions.
2. Disconnect the 2-pin power cable from the mainboard.

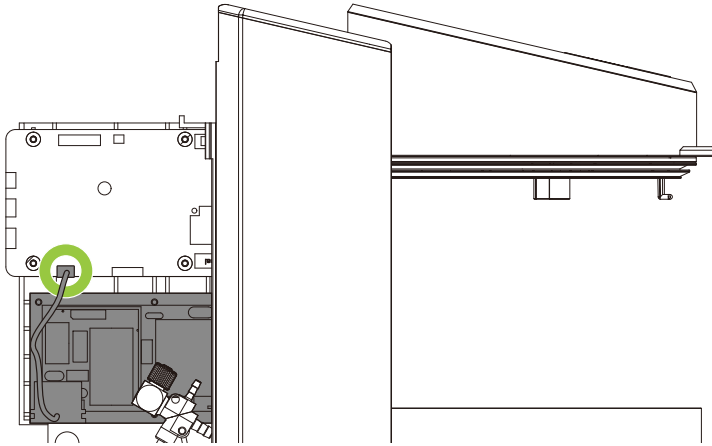

3. Remove the three black M2.5x5 round Phillips head self-tapping screws securing the power board in place and then carefully separate the board from its compartment from the machine.

**⚠ CAUTION:** DO NOT pull or attempt to completely remove the power board at this point as this will damage its AC cable connection.

**✓ NOTE:** If the space near the board is too tight, disconnect the 12-pin daughter board cable from the mainboard to create space to separate the power board.

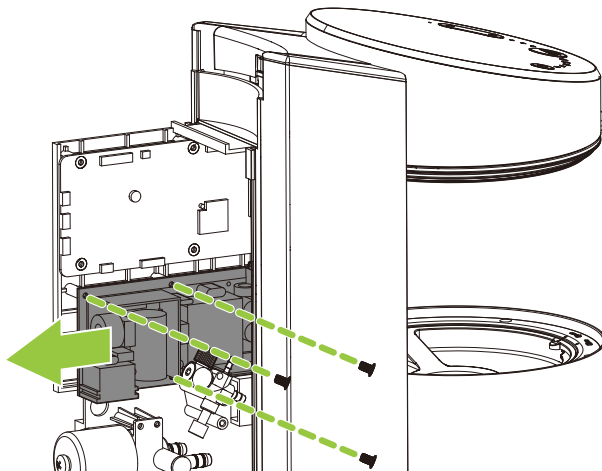

4. On the reverse side of the power board remove the soldering that connects the AC power cable to the board, and then remove the board from the machine.

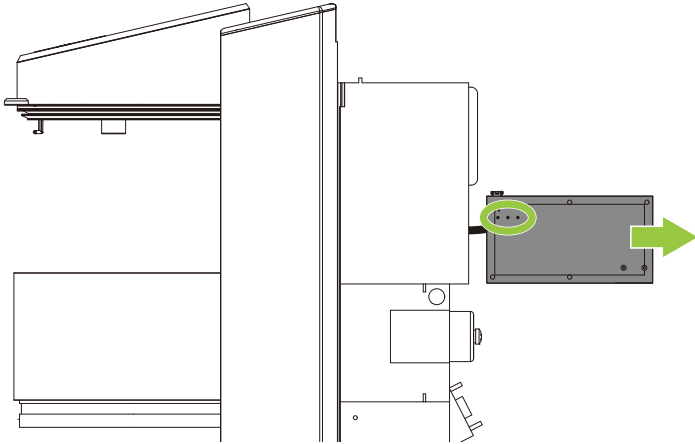

**NOTE:** When re-installing the power board, you must re-solder the AC power cable to the power board.

To install the power board, reverse the steps above.

## Replacing the Electromagnetic Valve

**NOTE:** Before removing the electromagnetic valve, ensure that you have already filled the upper pot with water and completed the self-cleaning mode on the machine to clean its tubes.

1. Remove the rear cover from the machine. See “Removing the Rear Cover” on page 11 for instructions.
2. Disconnect the 2-pin electromagnetic valve cable from the mainboard.

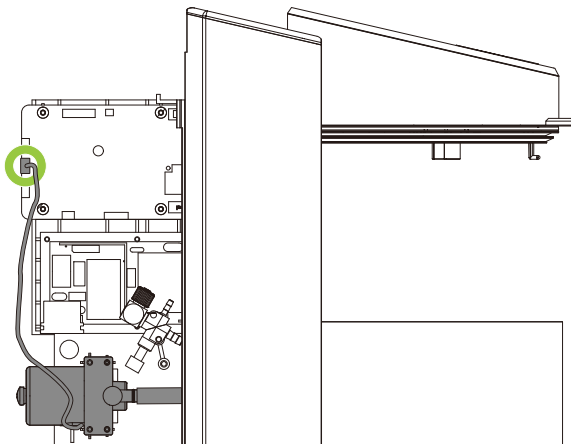

**✓ NOTE:** The cable is bundled together with several other cables with a plastic cable tie which must be cut in order to remove the electromagnetic valve. After replacing the valve, re-bundle the cables together with a new cable tie in the same location.

3. Disconnect the (A) output and (B) intake tubes from the electromagnetic valve.

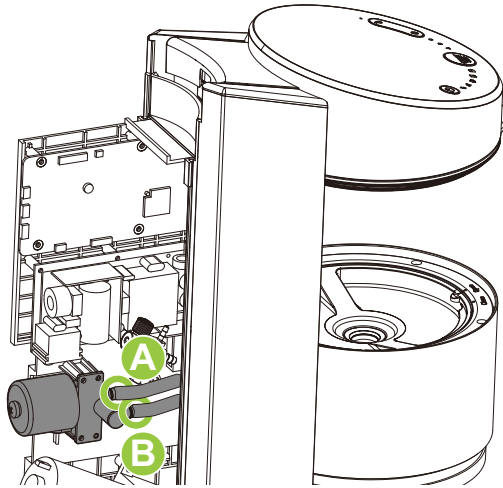

**✓ NOTE:** When re-installing, ensure that the liquid output tube is connected to the (A) inner valve and the liquid intake tube is connected to the (B) outer valve.

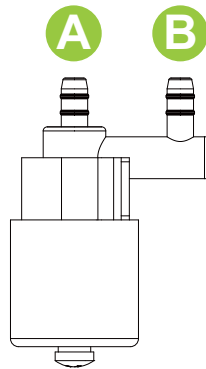

4. Remove the two black M2.5x5 round Phillips head self-tapping screws securing the electromagnetic valve in place and then remove the valve from the machine.

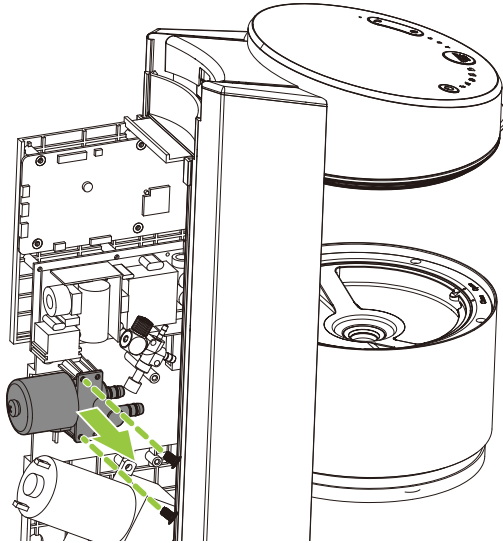

To install the electromagnetic valve, reverse the steps above.

## Cleaning the Electromagnetic Valve

1. Remove the electromagnetic valve from the machine. See “Replacing the Electromagnetic Valve” on page 21 for instructions.
2. Remove the two M3x6.2 machine-tapping screws securing the plastic cap in place, and then remove the cap from the electromagnetic valve.

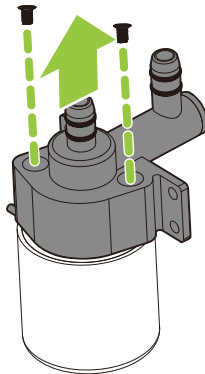

3. Remove the module for the membrane from the electromagnetic valve.

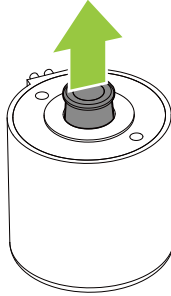

4. Wipe the (A) plastic cap, (B) membrane module and (C) electromagnetic valve completely clean of any coffee grounds or particles.

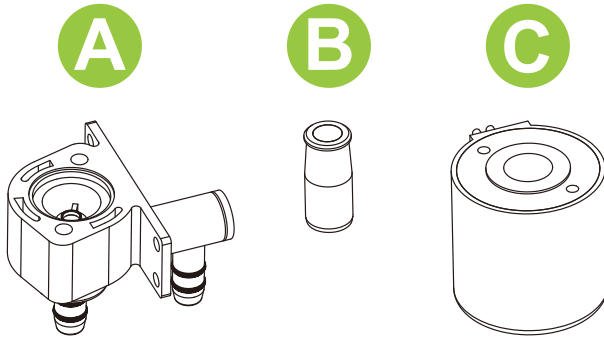

**✓ NOTE:** If the O-ring in the plastic cap falls out or gets dislodged during the cleaning process, ensure that the O-ring is re-installed into the cap. Failure to re-install the O-ring may cause the electromagnetic valve to not work correctly.

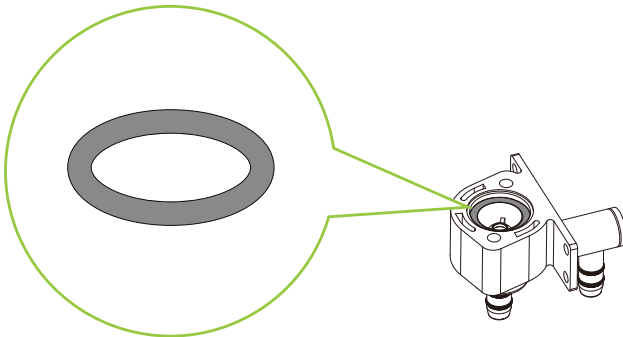

5. Reverse the steps above to re-install the electromagnetic valve.



# Replacing the Pump

1. Remove the rear cover from the machine. See "Removing the Rear Cover" on page 11 for instructions.
2. Disconnect the 3-pin pump cable from the mainboard.

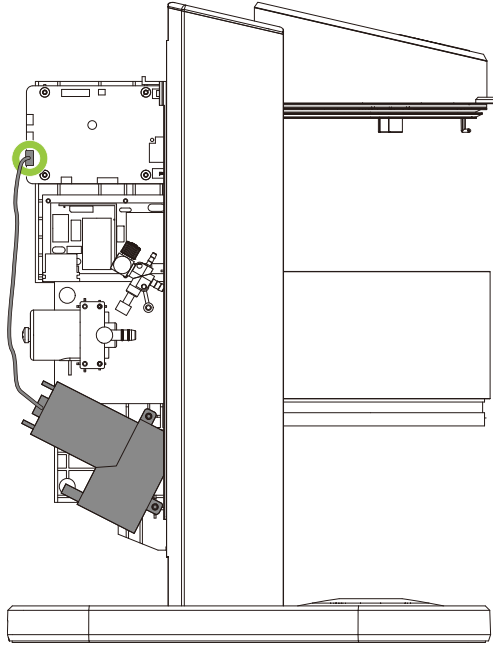

**✓ NOTE:** The cable is bundled together with several other cables with a plastic cable tie which must be cut in order to remove the pump. After replacing the pump, re-bundle the cables together with a new cable tie in the same location.

3. Disconnect the (A) suction tube and (B) discharge tube from the pump.

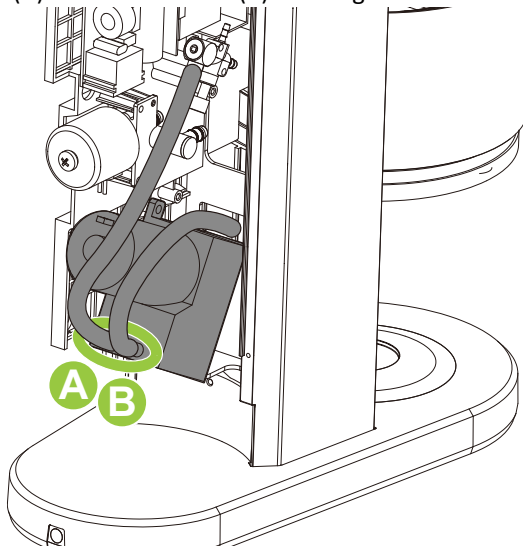

**✓ NOTE:** When re-installing the pump, ensure that the discharge tube is tucked into the interior of the machine after reconnecting the tube to the pump and that it not bent or clogged when it is tucked.

4. Remove the two black stainless steel M3x8 round Phillips head machine-tapping screws securing the pump in place, and then remove the pump from the machine.

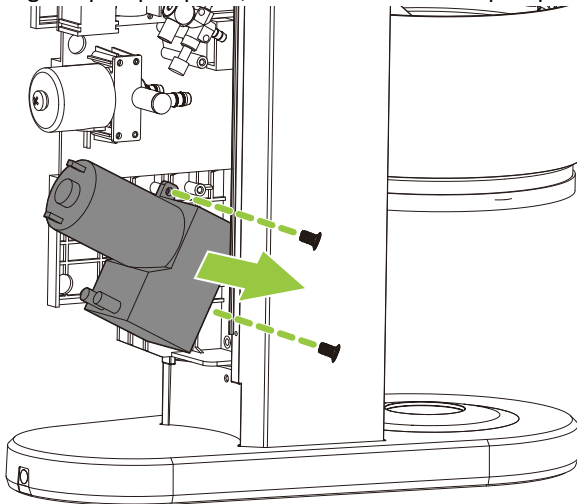

**✓ NOTE:** The two screws for the pump may be covered by sealant, if so use pliers to remove the sealant before removing the screws and then re-apply sealant over the two screws when you have finished re-installing the pump.

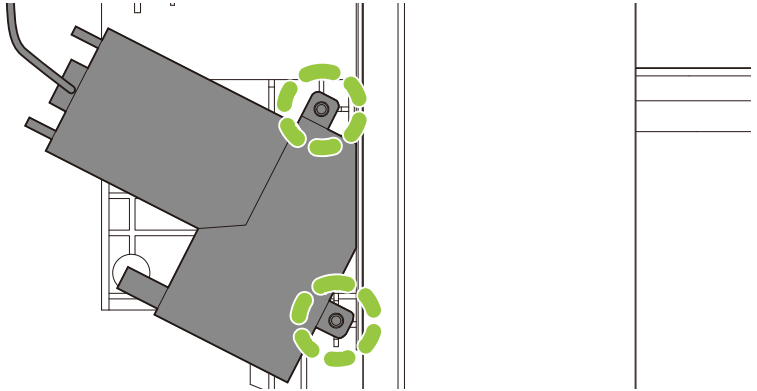

To install the pump, reverse the steps above.

# Opening the Middle Console Cover

1. Remove the four black stainless steel M2.5x8 countersunk Phillips head machine-tapping screws securing the middle console cover in place.

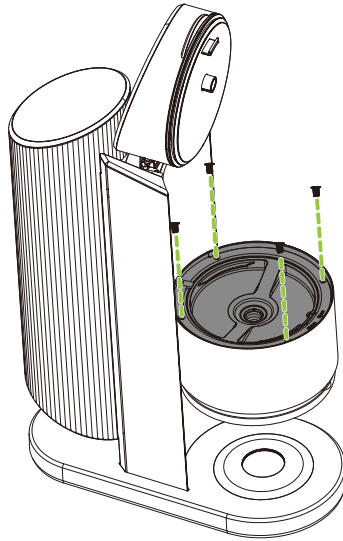

**✓ NOTE:** When re-installing the middle console cover, **DO NOT** fully tighten the four screws as tightening each screw fully will prevent the machine from working properly. Instead, first press the cover down at the area near each screw hole and then only tighten each screw until its head is level with its adjacent surface.

2. Lift and flip open the middle console cover from its left side.

**⚠ CAUTION:** **DO NOT** pull or attempt to completely remove the cover at this point as this will damage the middle console sensor board cable.

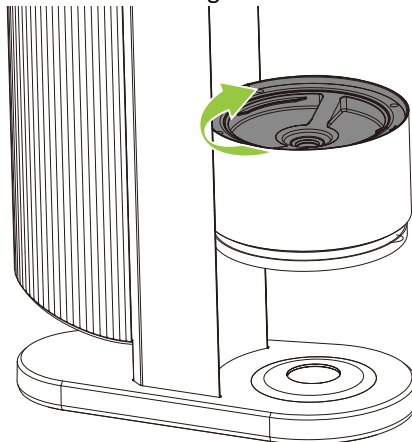

3. Disconnect the electromagnetic valve intake tube from the underside of the middle console cover.

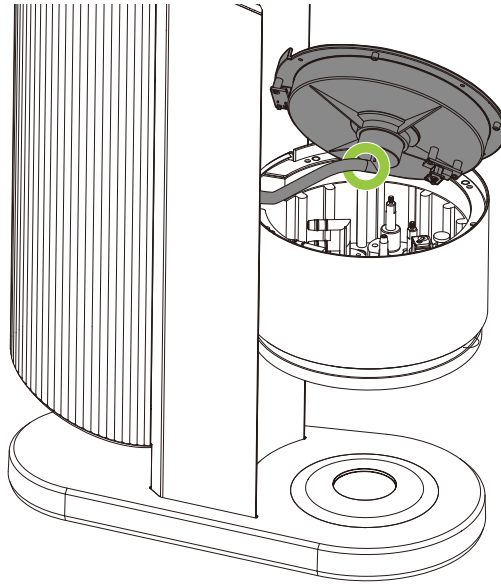

4. Move the console cover to the side in order to access the remaining parts.

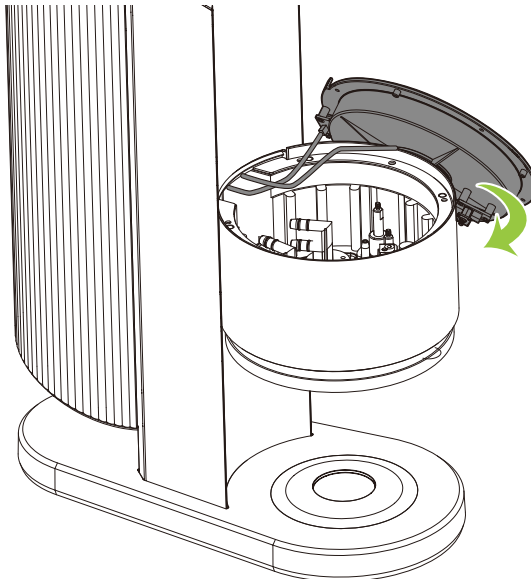

**✓ NOTE:** The middle console cover will still remain attached to the machine via the middle console sensor board cable.

To re-install the cover, reverse the steps above.

# Replacing the Middle Console Sensor Board

1. Open the middle console cover. See “Opening the Middle Console Cover” on page 28 for instructions.
2. Disconnect the middle console sensor board cable from the sensor board.

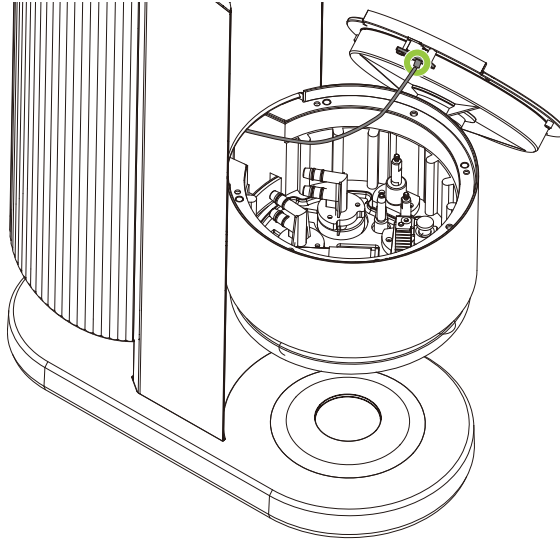

3. Remove the two black M2.5x5 Phillips head self-tapping screws securing the middle console sensor board in place, and then remove the board from the middle console cover.

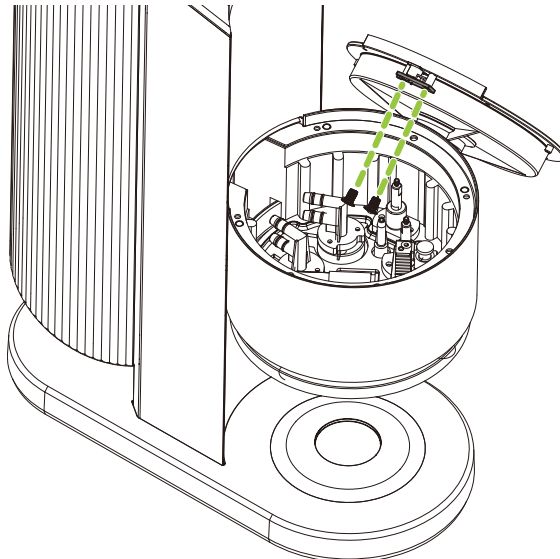

To install the middle console sensor board, reverse the steps above.

# Replacing the Lower Pot Cover Motor

1. Remove the rear cover from the machine. See “Removing the Rear Cover” on page 11 for instructions.
2. Disconnect the 3-pin lower pot cover motor cable from the mainboard.

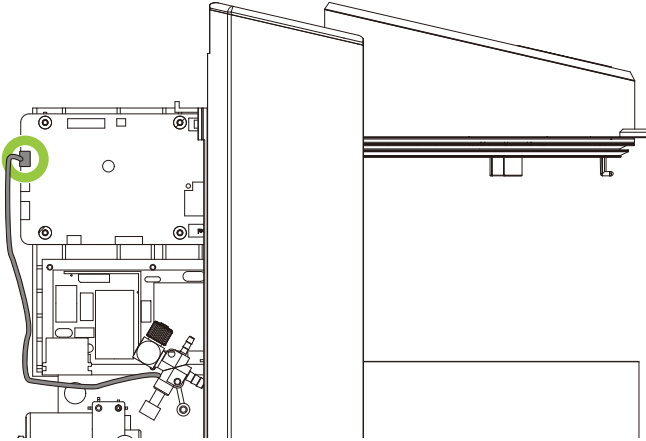

3. Open the middle console cover. See “Opening the Middle Console Cover” on page 28 for instructions.
4. Remove the three M2.5x4 round Phillips head machine-tapping screws securing the lower pot cover motor in place.

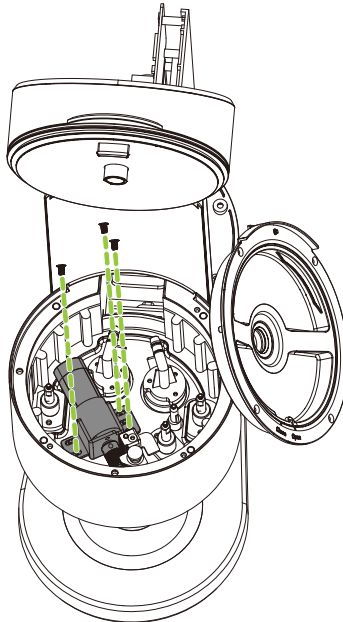

5. Push the lower pot cover motor to the left and then lift it out while unthreading the cable from the inside of the machine to remove the motor.

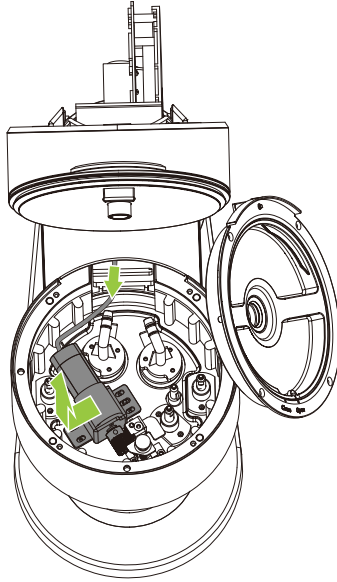

6. Loosen the M3x5 hexagonal Nylok set screw securing the rotary head in place and then remove the head from the motor.

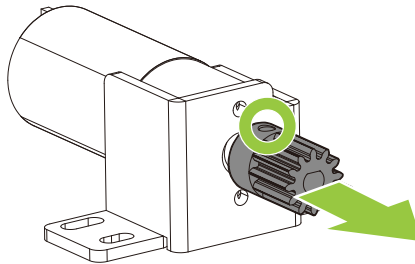

7. Remove the two M2.5x4 round Phillips head machine-tapping screws securing the motor bracket in place and then remove the bracket from the motor.

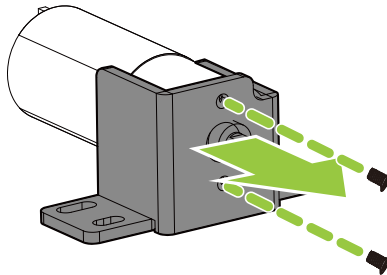

To install the lower pot cover motor, reverse the steps above. Ensure you also follow the cable routing instructions in “Lower Pot Cover Motor Cable” on page 63



# Correcting the Lower Pot Cover Pressure

1. Open the middle console cover. See “Opening the Middle Console Cover” on page 28 for instructions.
2. Rotate the lower pot cover pressure screw counter-clockwise 90 degrees (1/4 a rotation).

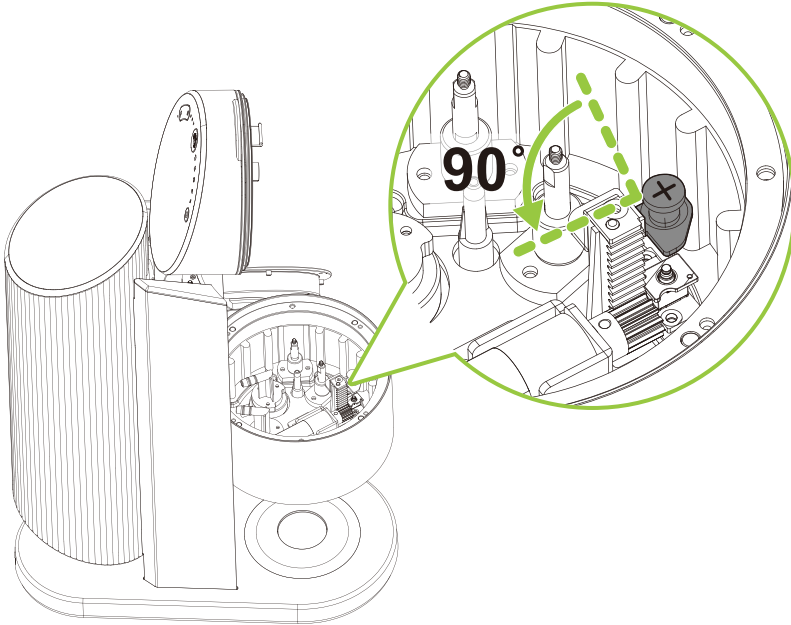

**✓ NOTE:** The screw for the lower pot cover may be covered by sealant, if so use pliers to remove the sealant before removing the screw. Then once you have successfully corrected the pressure based on the steps below, re-apply sealant in the location indicated in the image below.

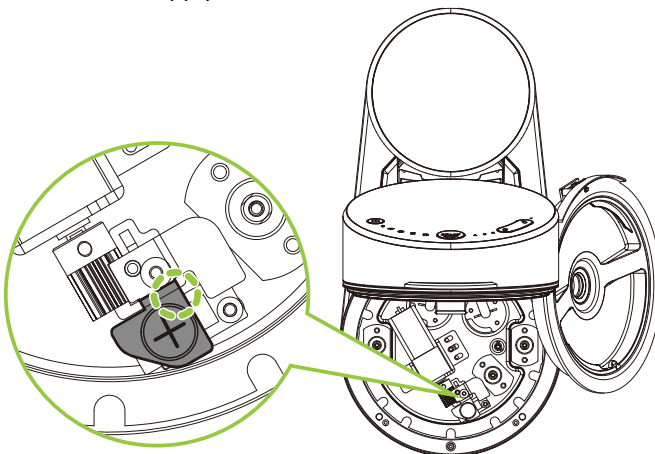

3. Fully re-assemble the machine.
4. Place the lower pot into its compartment so that its handle is oriented towards one side of the machine.

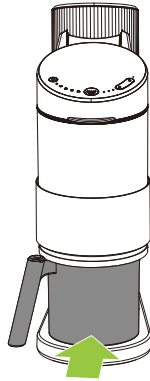

5. Run the coffee-making process one time and then proceed with the corresponding action based on whichever one of the following scenarios you encounter:
  - If the sound that the pump makes fluctuates between a high and low frequency, it means that the lower pot cover is working correctly and is properly pressure sealing the lower pot. Proceed with the following step.
  - If the sound that the pump makes is at a steady frequency, it means that the lower pot cover does not fully cover and pressure seal the lower pot. Repeat the steps described above until the pumps sound returns to the normal fluctuation between a high and low frequency.
6. Stop the suction process, restart the machine, rotate the lower pot so its handle is oriented in the opposite direction, and then run the coffee-making process again.

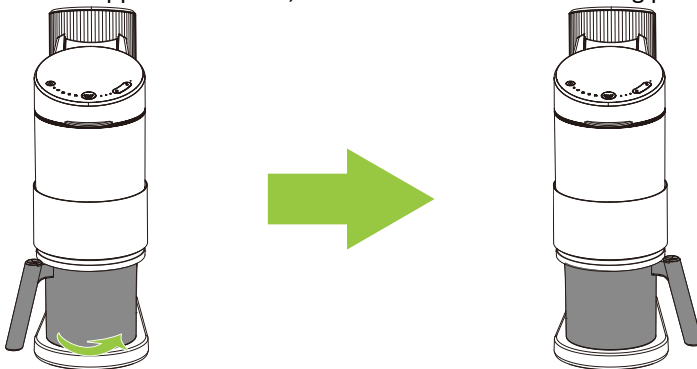

7. Follow the instructions in step 5 to determine if the sound that the pump makes is the normal high and low fluctuation. If the sound is at a steady frequency repeat steps 1 to 6 until it reverts back to its normal mode of operation.

# Securing the Lower Pot Cover Motor

1. Open the middle console cover. See “Opening the Middle Console Cover” on page 28 for instructions.
2. Check if the rotary head at the tip of the motor is fitted securely into teeth of the conveyor beam.
3. If not, remove the three M2.5x4 round Phillips head machine-tapping screws securing the lower pot cover motor in place and then push the motor toward the inside of the compartment so that the rotary head fits more securely and the screws are aligned as shown in the image below.

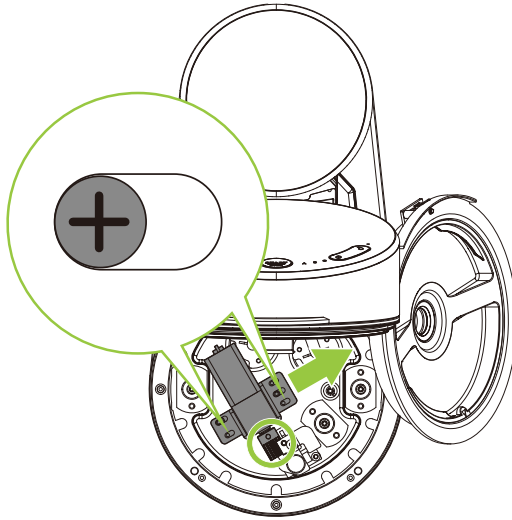

# Cleaning/Replacing the Liquid Intake/Output Tubes

1. Open the middle console cover. See “Opening the Middle Console Cover” on page 28 for instructions.
2. Disconnect (A) the output tube from the L-shaped connection tube of the middle console cover and (B) the intake tube from the connection tube in the middle console.

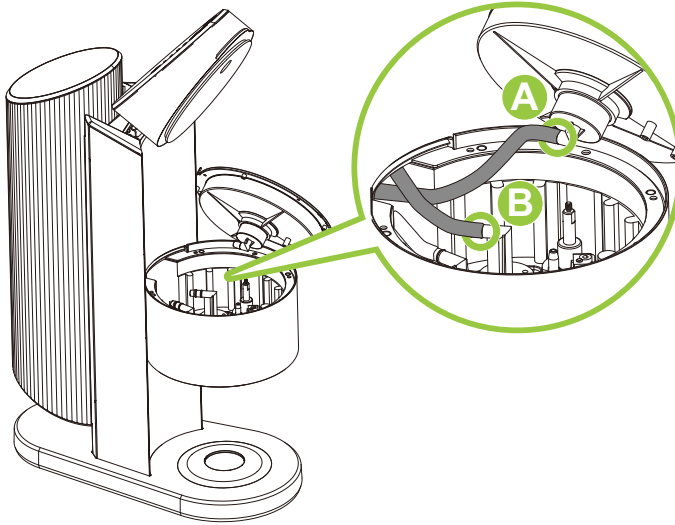

3. Remove the rear cover from the machine. See “Removing the Rear Cover” on page 11 for instructions.
4. Disconnect the (A) output and (B) intake tubes from the electromagnetic valve.

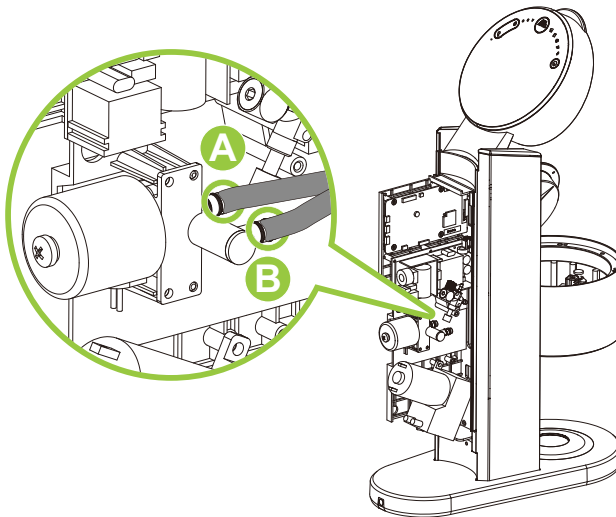

**✓ NOTE:** When re-installing the tubes, ensure that the liquid output tube is connected to the (A) inner valve and the liquid intake tube is connected to the (B) outer valve.

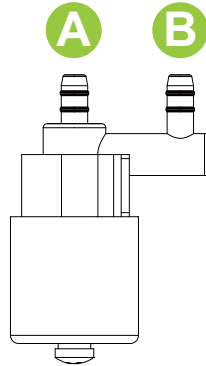

5. Remove both tubes from the machine.

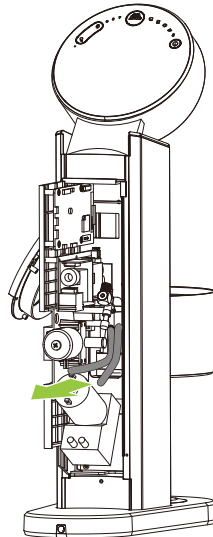

To install the intake/output tubes, reverse the steps above.

**✓ NOTE:** The tubes are tightly connected at each end with plastic cable ties. After replacing the tubes, re-secure the cable with new cable ties in the same locations.

# Removing the Top Cover

1. Remove the rear cover from the machine. See "Removing the Rear Cover" on page 11 for instructions.
2. Disconnect the 6-pin stirrer motor cable from the mainboard.

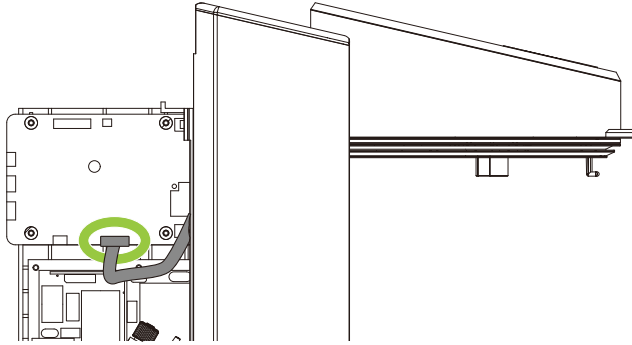

3. Remove the four black M2.5x5 round Phillips head self-tapping screws securing the mainboard in place and then carefully separate the mainboard from its compartment.

**⚠ CAUTION:** DO NOT pull or attempt to completely remove the mainboard at this point as this will damage the 12-pin operation panel cable.

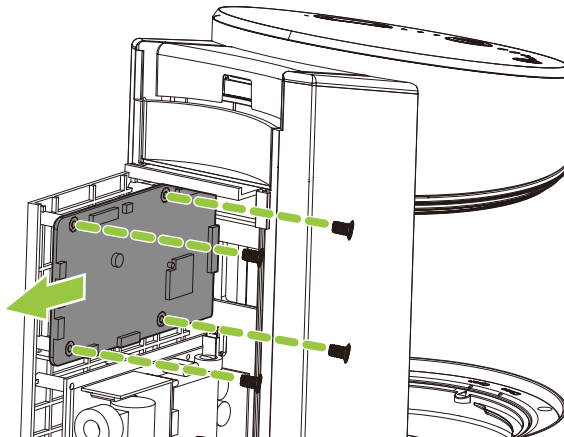

4. Disconnect the 12-pin operation panel cable from the mainboard.

**✓ NOTE:** The cable connector features a latch that requires the user to pinch in order to disconnect it from the mainboard.

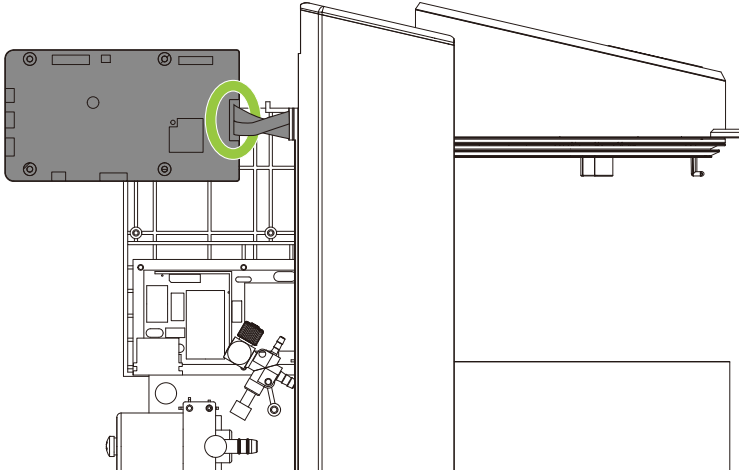

5. Remove the single M2.5x4 round Phillips head machine-tapping screw securing the hinge side cover in place, and then remove the cover from the machine.

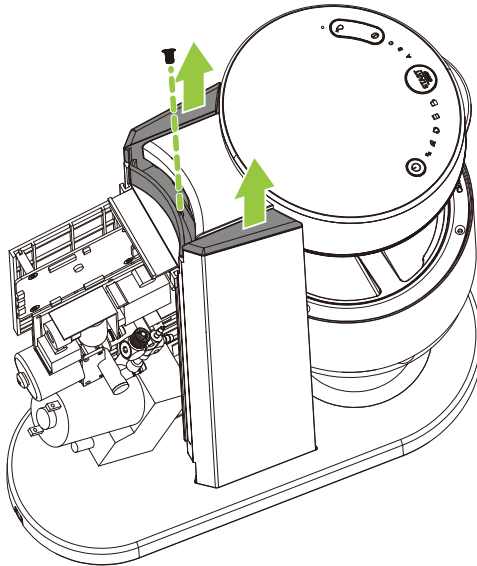

6. Remove the four M3x6 round Phillips head machine-tapping Nylok screws securing the top cover in place.

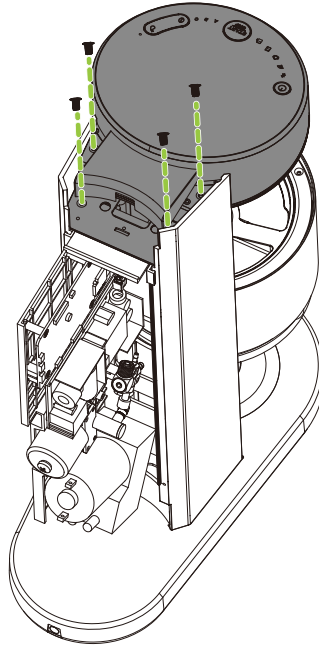

7. Lift the top cover off the machine while unthreading the cables through the opening in the machine.

**⚠ CAUTION:** DO NOT pull or attempt to completely remove the top cover at this point as this will damage its hinge board cable connection.

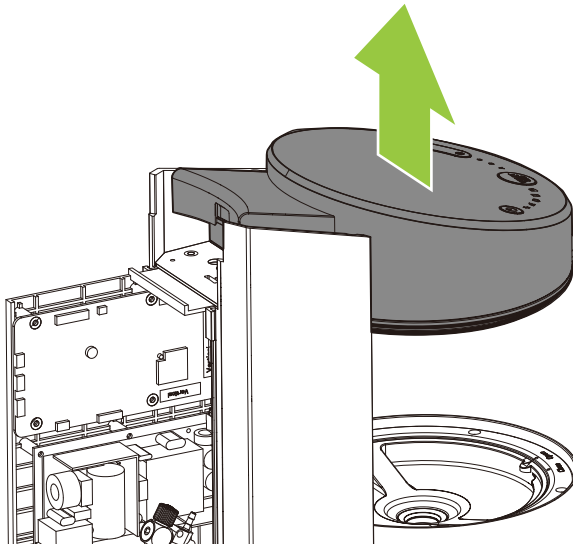



8. Disconnect the 12-pin daughter board cable from the hinge board.

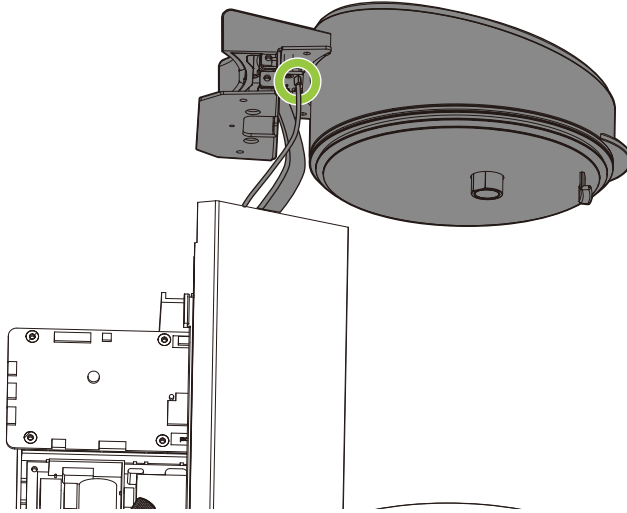

9. Unthread the cables from the inside of the machine while completely removing the top cover from the system.

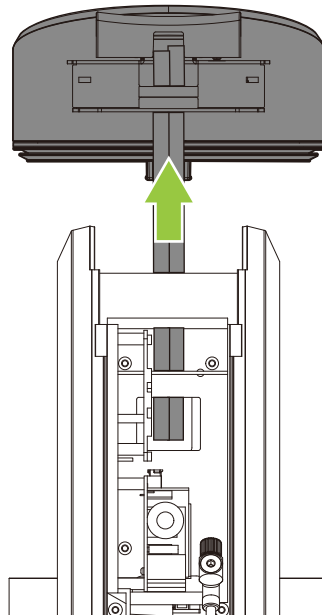

To re-install the top cover, reverse the steps above.

## Replacing the Hinge Board

1. Remove the top cover from the machine. See “Removing the Top Cover” on page 38 for instructions.
2. Remove the two M2.5x6 round Phillips head machine-tapping screws securing the hinge board in place, and then remove the board from the system.

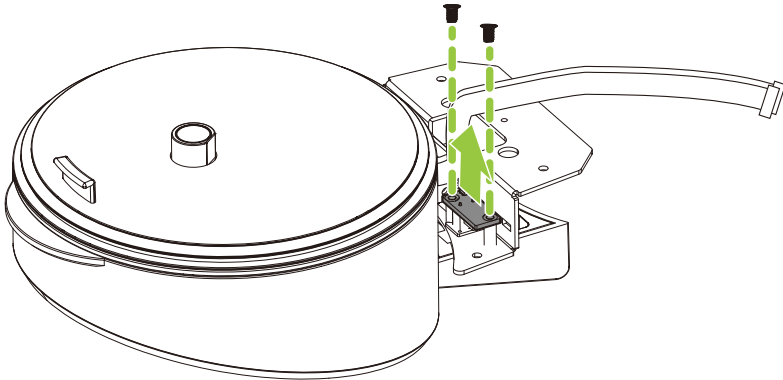

To install the hinge board, reverse the steps above.

## Replacing the Stirrer Motor

1. Remove the top cover from the machine. See “Removing the Top Cover” on page 38 for instructions.
2. Remove the top inner cover

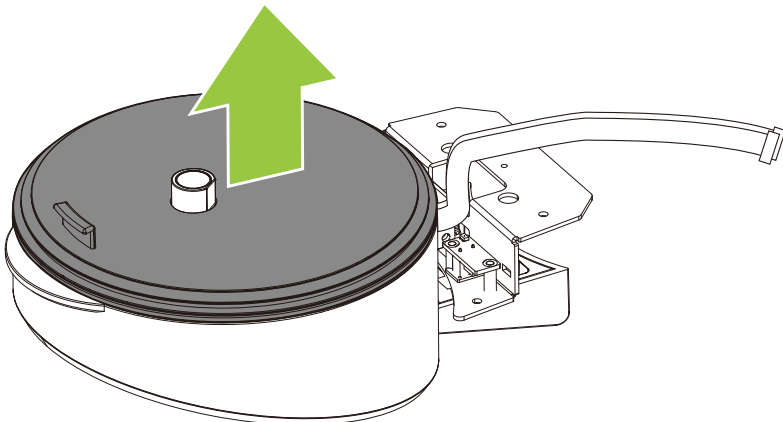

3. Remove the four black stainless steel M2.5x5 Phillips head self-tapping screws securing the operation panel in place.

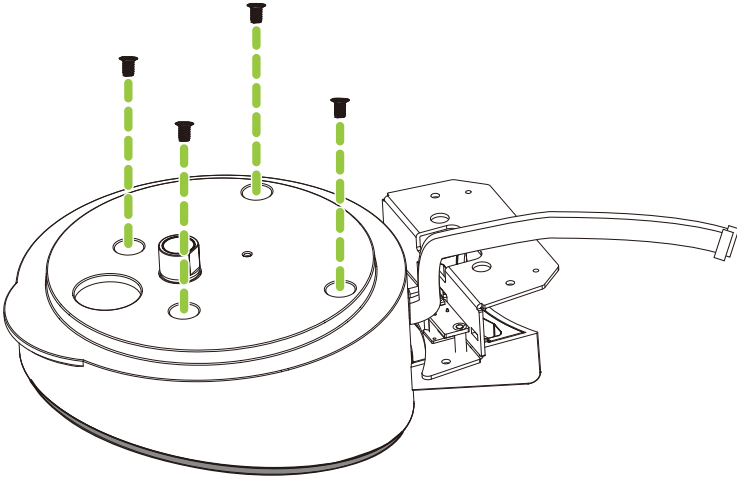

4. Lift and then flip open the operation panel.

**⚠ CAUTION:** DO NOT pull or attempt to completely remove the operation panel at this point as this will damage its cable connections.

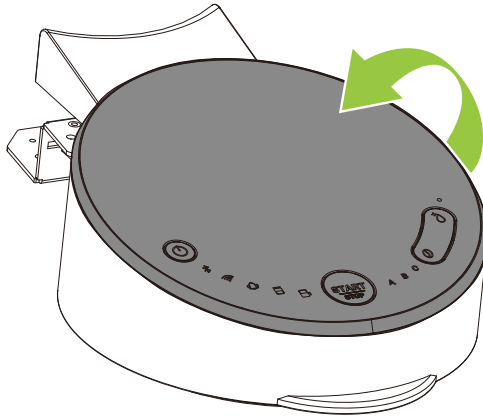

5. Disconnect the 6-pin stirrer motor cable from the motor.

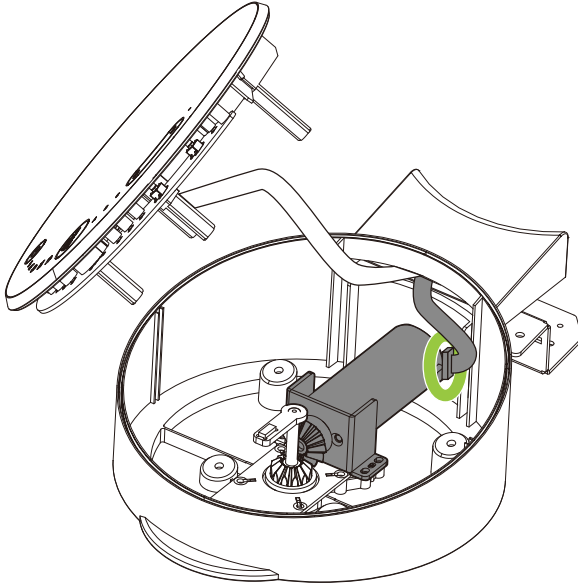

6. Remove the four black M2.5x5 Phillips head self-tapping screws securing the stirrer motor in place, and then lift the stirrer motor to remove it from the top cover.

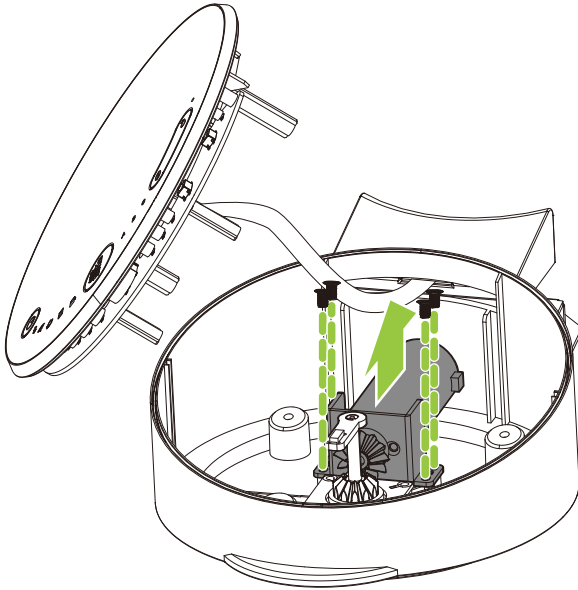

**NOTE:** If you are removing the stirrer motor to access and remove another part, you can skip the steps below and proceed to the steps for the respective part.

7. Loosen the M3x5 hexagonal Nylok set screw securing the rotary head in place and then remove the head from the motor.

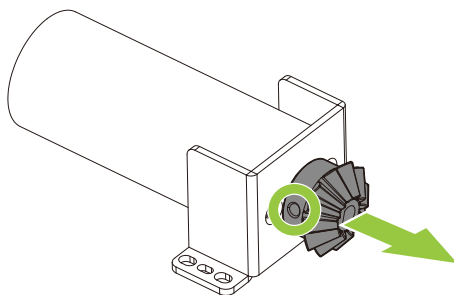

8. Remove the two black M3x6 countersunk Phillips head machine-tapping screws securing the motor bracket in place and then remove the bracket from the motor.

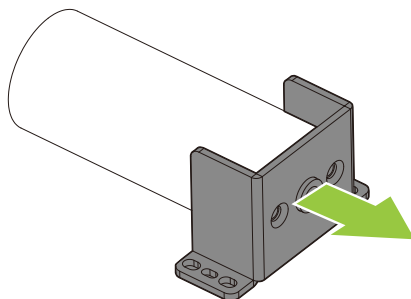

To install the stirrer motor, reverse the steps above.

# Securing the Stirrer Motor

1. Follow steps 1 - 3 in the Stirrer Motor section to open the operation panel. See “Replacing the Stirrer Motor” on page 42 for instructions.
2. Check if the alignment pegs between each pair of screws that secure the stirrer motor in place is aligned in the position shown in the image below.
3. If not, remove the four black M2.5x5 Phillips head self-tapping screws securing the stirrer motor in place and then push the motor toward the rear of the top cover so that the alignment peg is aligned as shown in the image below.

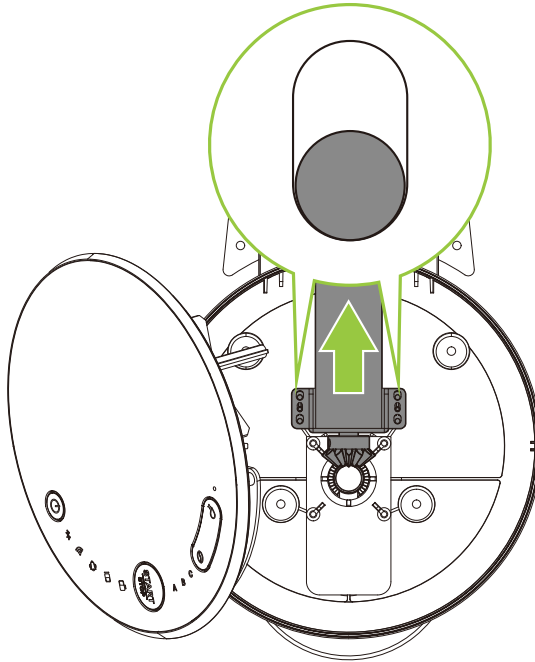

# Replacing the Plastic Rotary Head

1. Remove the stirrer motor. See “Replacing the Stirrer Motor” on page 42 for instructions.
2. Remove the four black M2.5x5 Phillips head self-tapping screws securing the plastic rotary head bracket in place, and then remove the bracket from the machine.

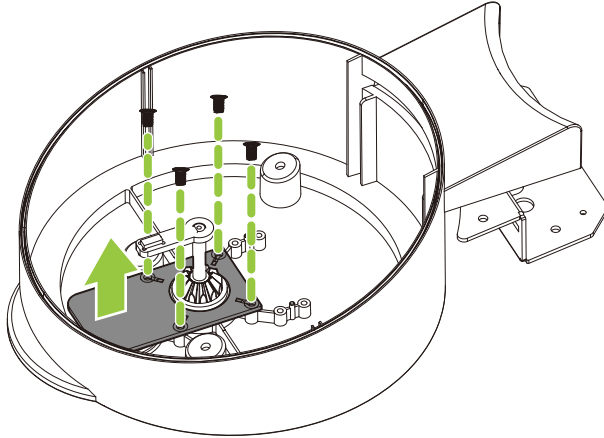

3. Remove the plastic rotary head from the machine.

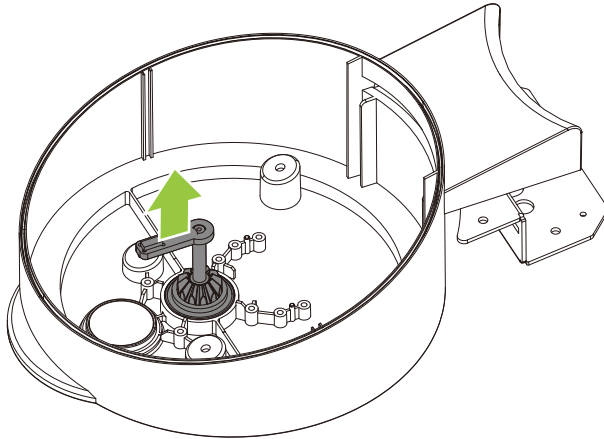

4. Remove the single black M2x5 Phillips head self-tapping screw securing the plastic rotary head's magnet in place, and then remove the M2 stainless steel washer and magnet from the rotary head.

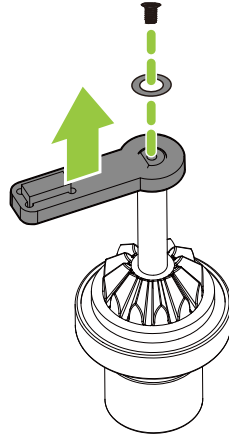

5. Pull the plastic rotary head out from its metal ring to remove it.

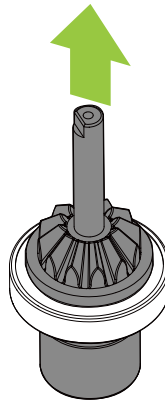

**✓ NOTE:** When re-installing the plastic rotary head, ensure that you push it down fully so that it is fully secure in the metal ring.

To install the plastic rotary head, reverse the steps above.



# Replacing the Button Board

1. Follow steps 1 - 3 in the Stirrer Motor section to open the operation panel. See "Replacing the Stirrer Motor" on page 42 for instructions.
2. Disconnect the 12-pin button board cable from the button board and cut the plastic cable tie tying the cable to operation panel.

**✓ NOTE:** The cable connector features a latch that requires the user to pinch in order to disconnect it from the button board.

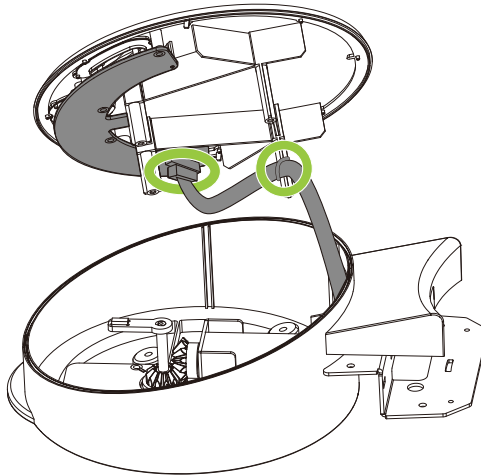

**✓ NOTE:** When replacing the button board, re-tie the button board cable to the operation panel in the same location using a cable tie.

3. Remove the four black M2.5x5 Phillips head self-tapping screws securing the button board in place, and then remove it from the operation panel.

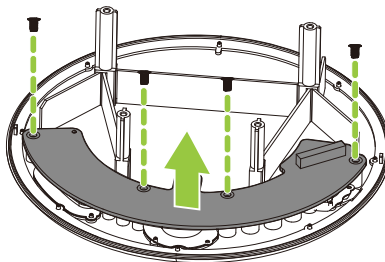

**✓ NOTE:** After the button board has been re-installed onto the top cover, press each of the button on the operation panel to test them. If any of the buttons cannot be pressed properly, slightly loosen the screw on the button board closest to the respective button.

To install the button board, reverse the steps above.

# Removing the Hinge

1. Remove the top cover from the machine. See “Removing the Top Cover” on page 38 for instructions.
2. Remove the two black M2.5x5 Phillips head machine-tapping screws securing the hinge to the top cover.

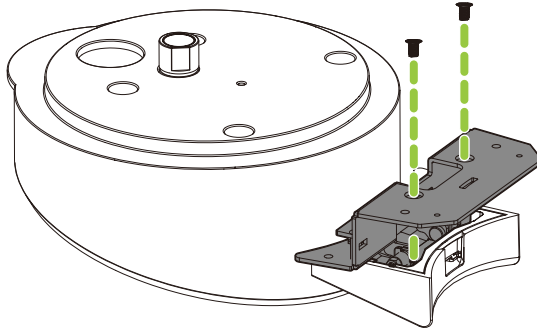

3. Rotate the hinge 90 degrees to a fully open angle.

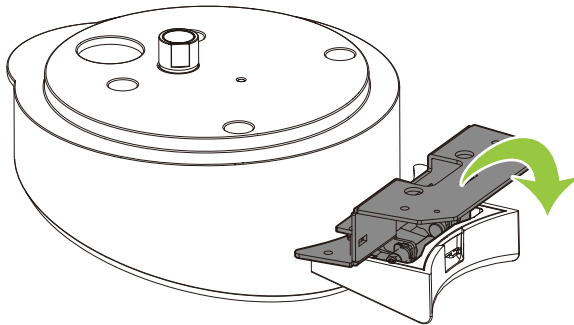

4. Remove the two remaining black M2.5x5 Phillips head machine-tapping screws securing the hinge to the top cover.

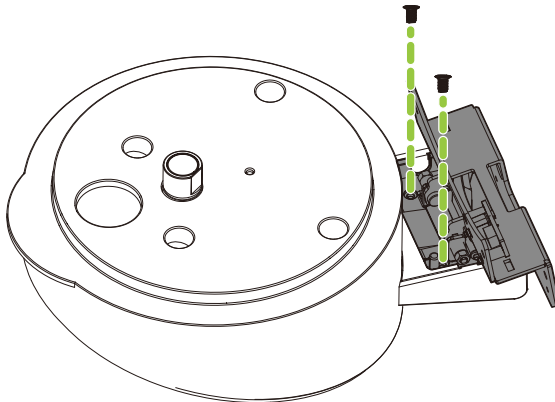

5. Remove the hinge from the top cover while unthreading the 6-pin stirrer motor cable and button board cable from the opening in the hinge.

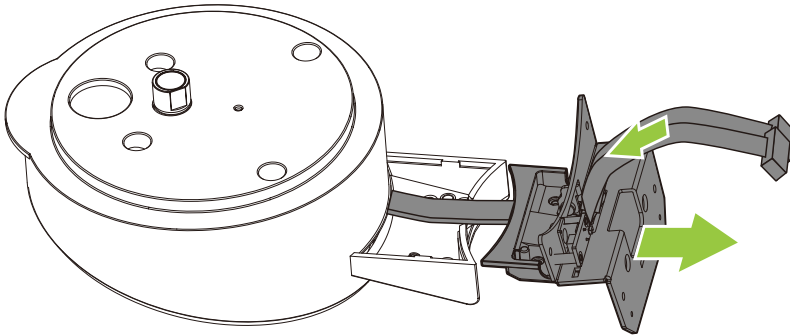

To re-install the hinge, reverse the steps above. Ensure you also follow the cable routing instructions in “Stirrer Motor and Button Board Cable” on page 59.

## Replacing the 6-Pin Stirrer Motor Cable

1. Remove the hinge. See “Removing the Hinge” on page 50 for instructions.
2. Follow steps 1 - 3 in the Stirrer Motor section to open the operation panel. See “Replacing the Stirrer Motor” on page 42 for instructions.
3. Disconnect the 6-pin stirrer motor cable from the motor.

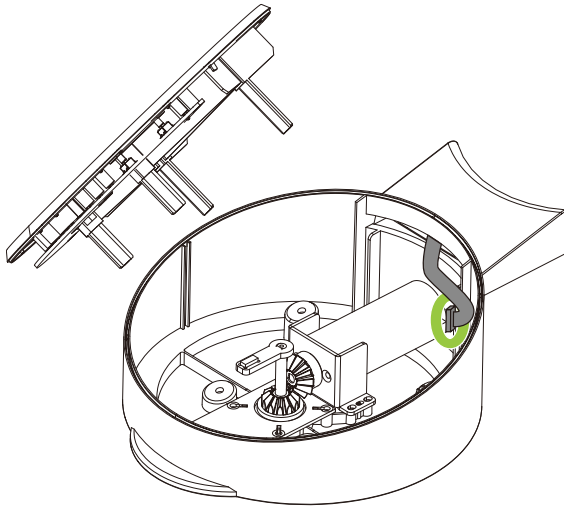

4. Unthread the 6-pin stirrer motor cable from the slit in the top cover to remove it.

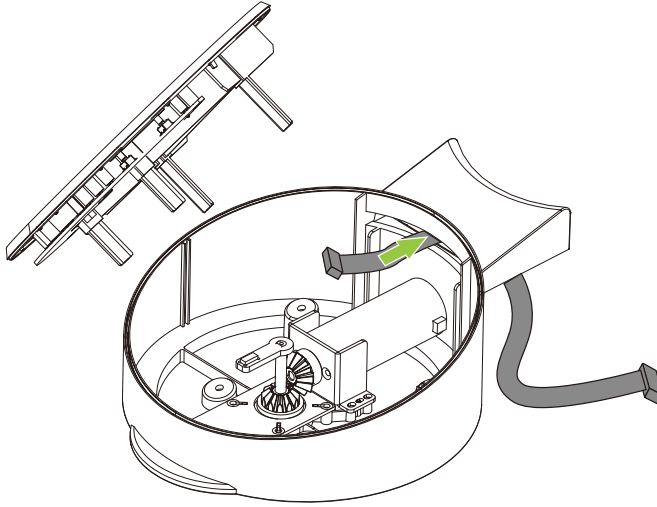

To install the 6-pin stirrer motor cable, reverse the steps above. Ensure you also follow the cable routing instructions in “Stirrer Motor and Button Board Cable” on page 59.

## Replacing the 12-Pin Button Board Cable

1. Remove the hinge. See “Removing the Hinge” on page 50 for instructions.
2. Follow steps 1 - 3 in the Stirrer Motor section to open the operation panel. See “Replacing the Stirrer Motor” on page 42 for instructions.
3. Disconnect the 12-pin button board cable from the button board.

 **NOTE:** The cable connector features a latch that requires the user to pinch in order to disconnect it from the button board.

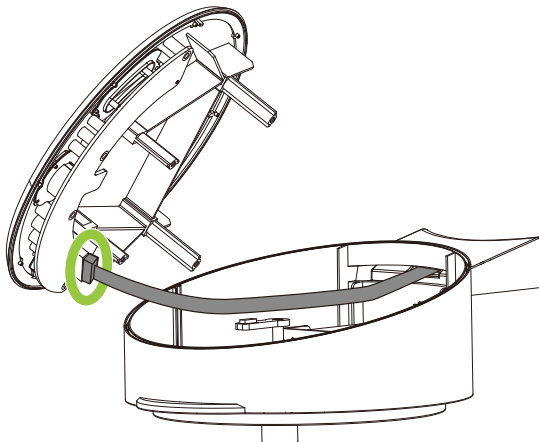

4. Unthread the 12-pin button board cable from the slit in the top cover to remove it.

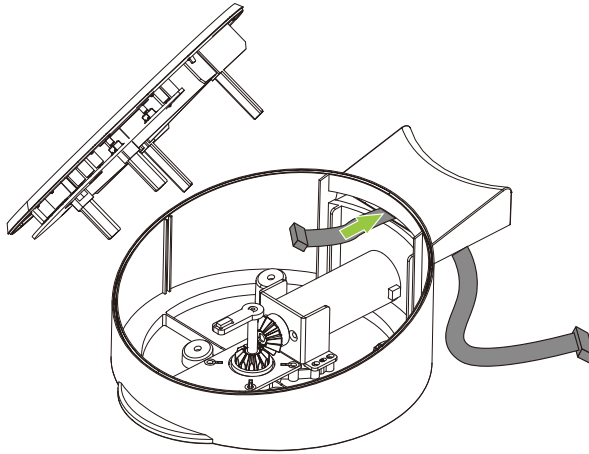

To install the 12-pin button cable, reverse the steps above. Ensure you also follow the cable routing instructions in “Stirrer Motor and Button Board Cable” on page 59.

## Replacing the Lower Pot Sensor Board

1. Remove the seven black stainless steel M3x8 round Phillips head self-tapping screws and eight silver stainless steel M3x6 round Phillips head machine-tapping Nylok screws securing the base panel in place and then remove the panel from the machine.

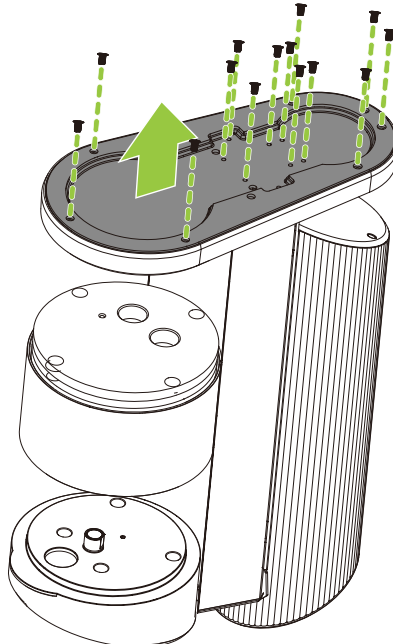

2. Disconnect the 12-pin daughter board cable from the lower pot sensor board.

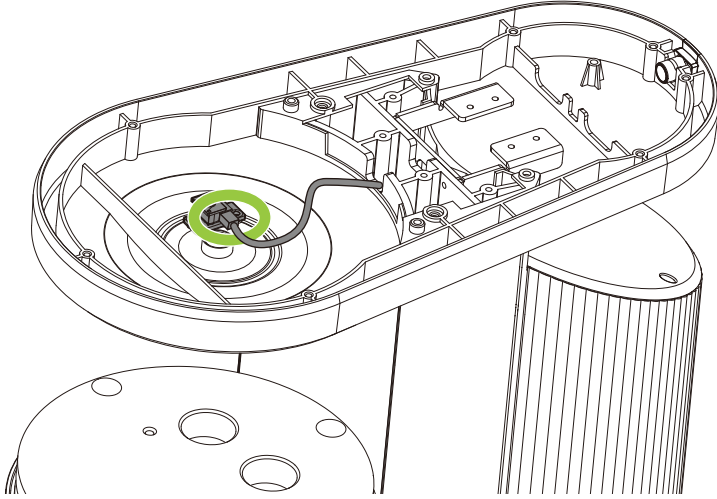

3. Remove the single black M2.5x5 Phillips head self-tapping screw securing the lower pot sensor board in place, and then remove the board.

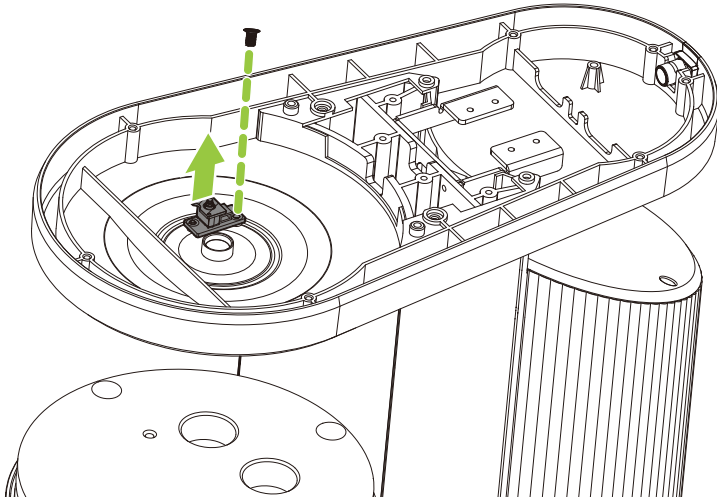

To install the lower pot sensor board, reverse the steps above.

# Replacing the 12-Pin Daughter Board Cable

**✓ NOTE:** The cable is secured in place at multiple locations with plastic cable ties which must be cut in order to remove the cable. After replacing the cable, re-secure the cable with new cable ties in the same locations.

1. Remove the seven black stainless steel M3x8 round Phillips head self-tapping screws and eight silver stainless steel M3x6 round Phillips head machine-tapping Nylok screws securing the base panel in place and then remove the panel from the machine.

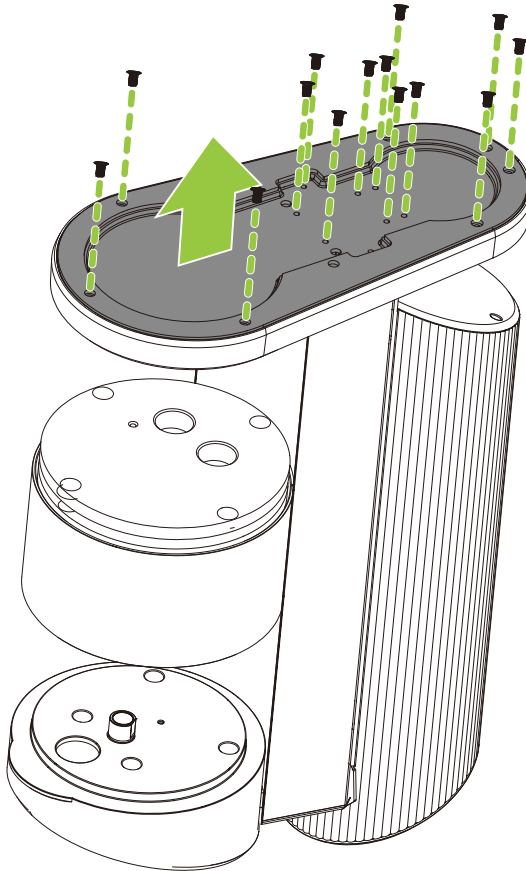

2. Disconnect the 12-pin daughter board cable from the lower pot sensor board.

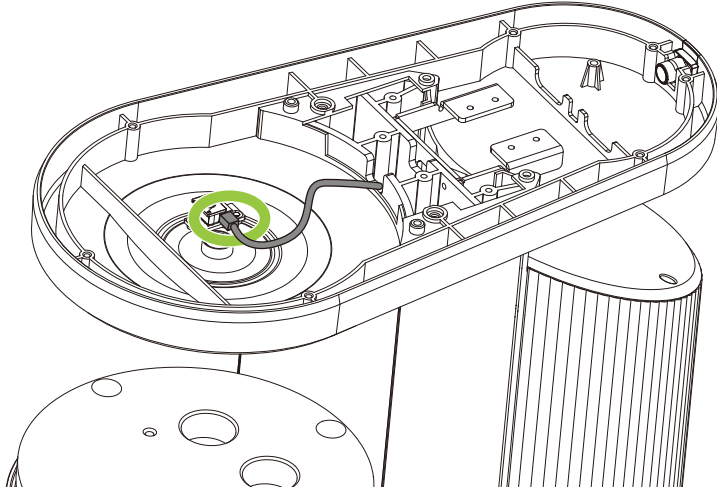

3. Remove the rear cover from the machine. See “Removing the Rear Cover” on page 11 for instructions.
4. Disconnect the 12-pin daughter board cable from the mainboard.

**NOTE:** The 12-pin daughter board cable connector features a latch that requires the user to pinch in order to disconnect it from the mainboard.

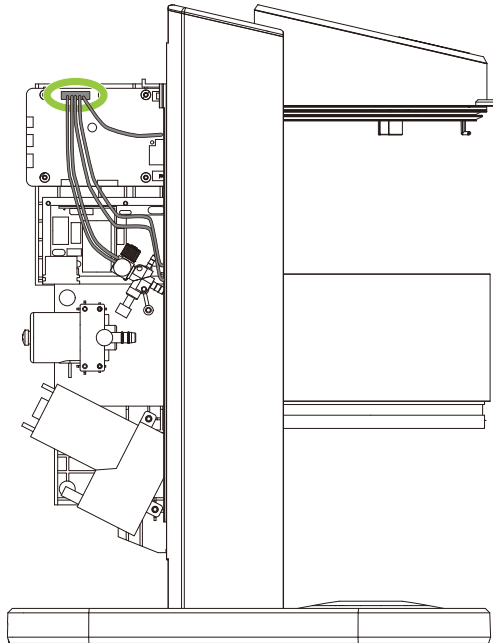



5. Follow steps 1 to 3 in the power board section to separate the power board from its compartment. See “Replacing the Power Board” on page 20 for instructions.
6. Open the middle console cover. See “Opening the Middle Console Cover” on page 28 for instructions.
7. Disconnect the 12-pin daughter board cable from the (A) middle console sensor board and (B) top lift sensor board.

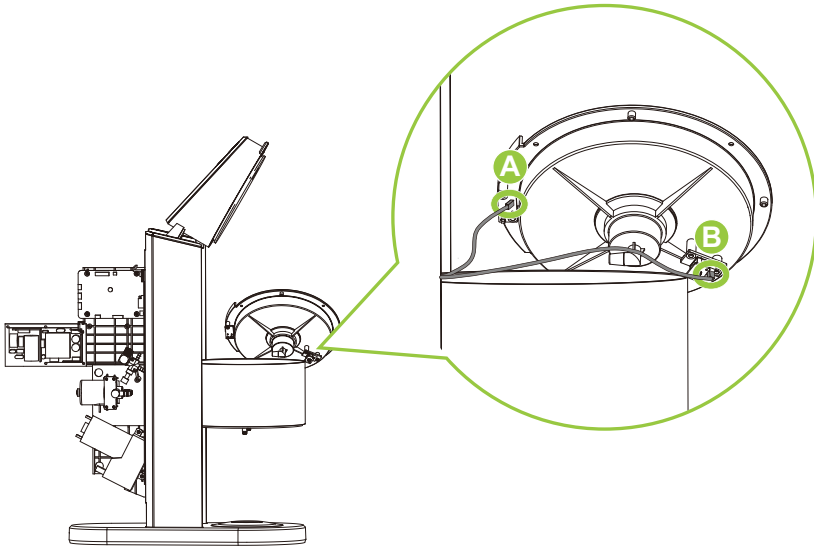

8. Remove the two black M2.5x6 round Phillips head machine-tapping Nylok screws securing the bottom lift sensor board and the single M3x6 round Phillips head machine-tapping Nylok screw securing the cable hook in place, and then remove the sensor board and the hook from their compartment.

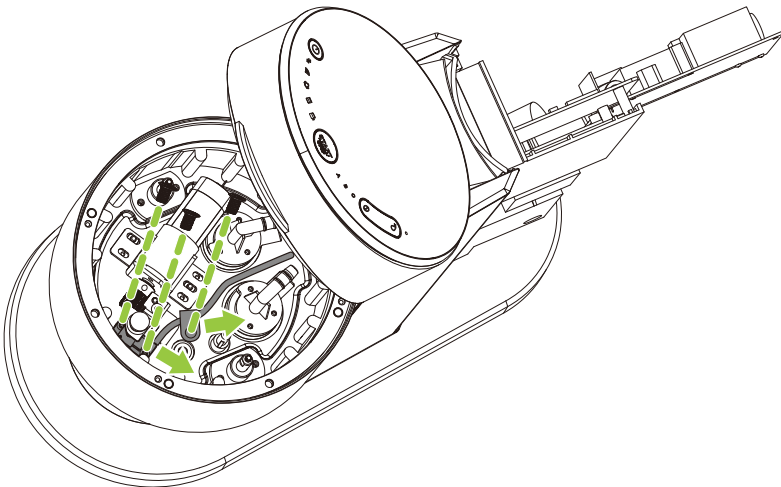

9. Disconnect the 12-pin daughter board cable from the bottom lift sensor board.

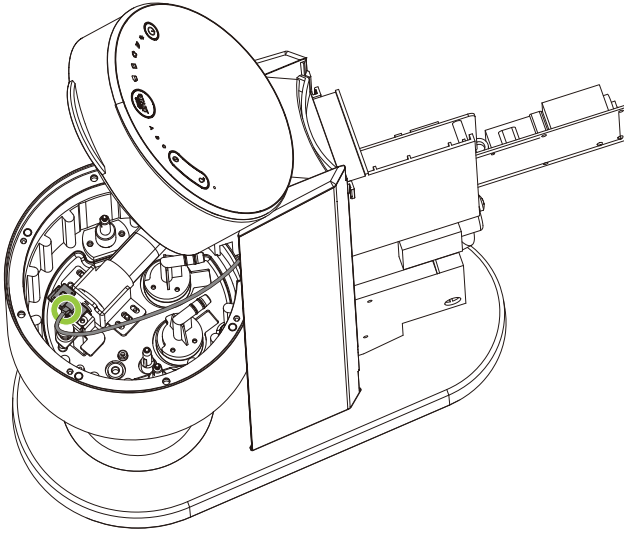

10. Follow steps 3 to 10 in the top cover section to disconnect the 12-pin daughter board cable from the hinge board. See “Removing the Top Cover” on page 38 for instructions.

11. Unthread the cable from the inside of the machine to remove it.

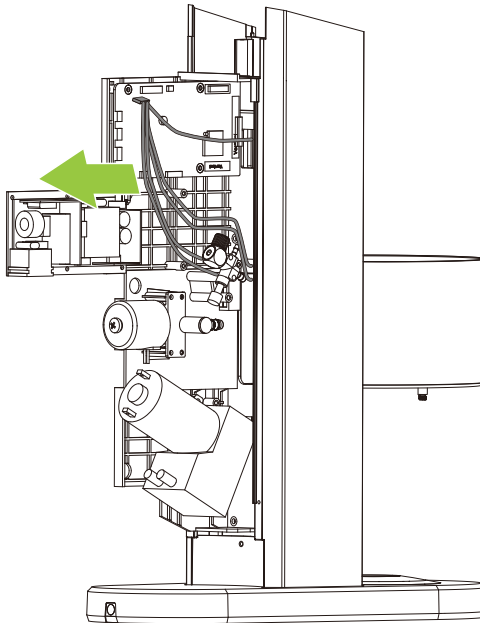

To install the 12-pin daughter board cable, reverse the steps above. Ensure you also follow the cable routing instructions in “12-Pin Daughter Board Cable” on page 61.

# Cable Routing

## Stirrer Motor and Button Board Cable

When routing the stirrer motor and button board cable, follow the instructions below:

1. Thread the two cables through the slit at the rear of the top cover.

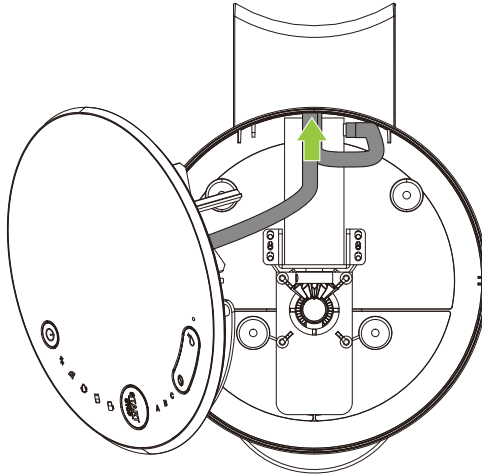

2. Route the two cables squarely in the center of the U-shaped cut-out/gap at the rear of the top cover.

**⚠ CAUTION:** The cables **MUST** be tightly routed in the center of the cut-out/gap, if not they will be damaged by the hinge.

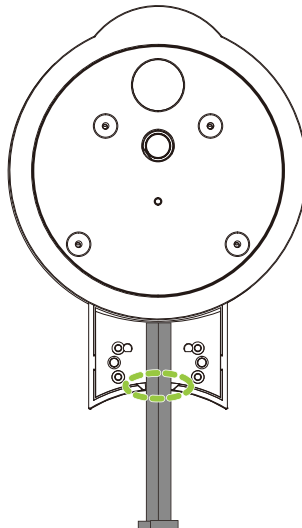

3. Install the hinge into its compartment on the top cover and install the two black M2.5x5 Phillips head machine-tapping screws to secure the hinge in place.

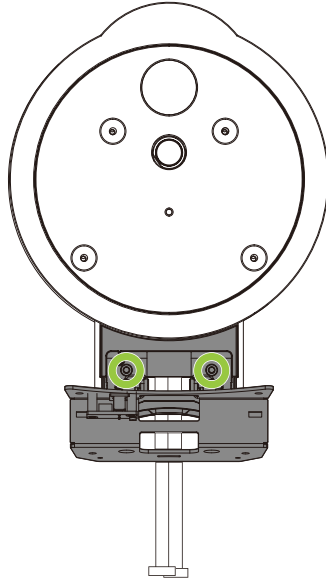

4. Thread the two cables through the middle opening in the hinge.

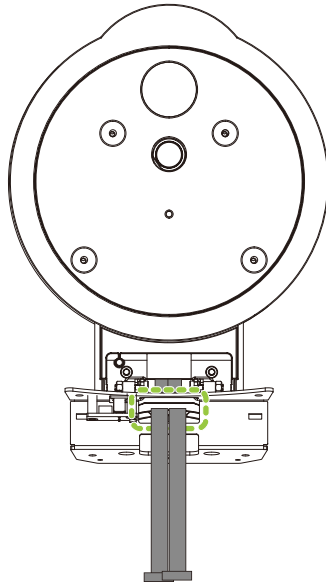

5. Tug on the two cables to check if there is slack and that they are not being squeezed/impinged by the hinge. If there is not any slack on the cables, remove the hinge and then repeat the steps above.

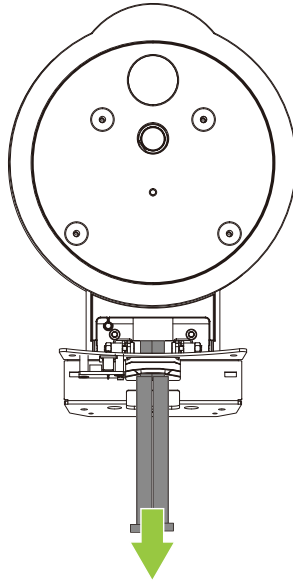

## 12-Pin Daughter Board Cable

When routing the 12-pin daughter board cable, follow the instructions below:

- Route the (A) hinge board cable (labeled “CoverR”) through the opening at the top of the machine’s middle column.

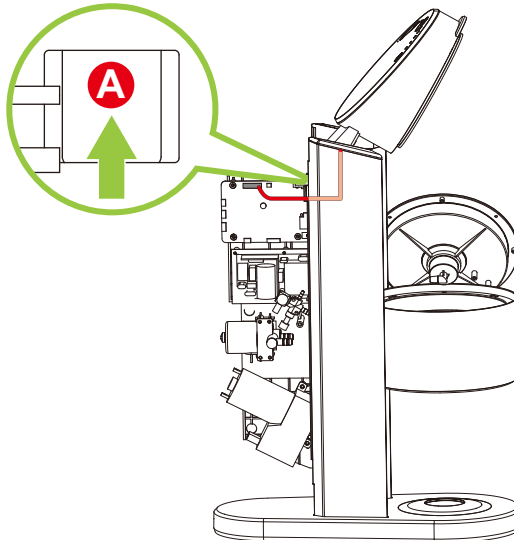

- Route the (B) middle console sensor cable (labeled “Tcup”) and (C) top lift sensor board cable (labeled “TLIFT”) through the opening in the center of the machine’s middle column.

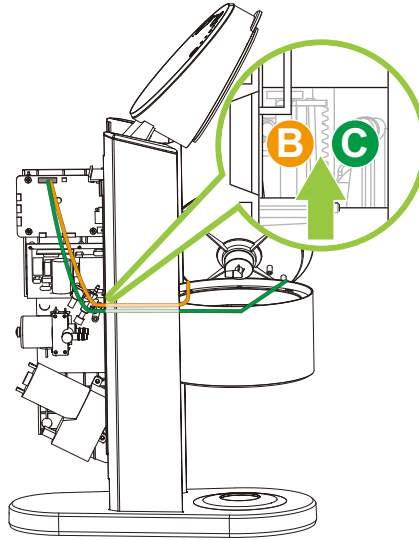

- Route the (D) bottom lift sensor cable (labeled “BLIFT”) and (E) lower pot sensor cable (labeled “BcuP”) through the routing channel and then through the opening in the center of the machine’s middle column. Afterwards, route the bottom lift sensor cable into the middle console, and the lower pot sensor cable into the base of the machine.

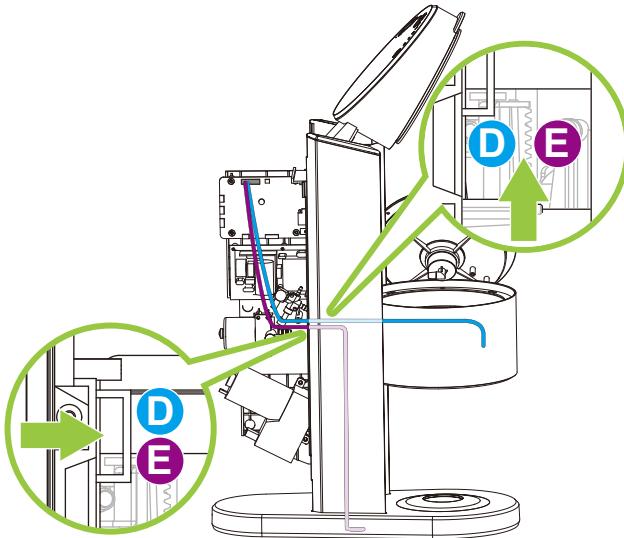

## Lower Pot Cover Motor Cable

When routing the lower pot cover motor cable, route the cable through the routing channel and then through the opening in the center of the machine's middle column.

